



**MY24 & BEYOND
SILVERADO MED DUTY
CONFIGURATION DIAGRAMS
C/K(56043)**

CONFIGURATION DIAGRAMS - GENERAL INFORMATION

Model:	C56043 K56043
Cab:	CREW CAB

CA	WB
60"	175"
84"	199"
104"	219"
120"	235"

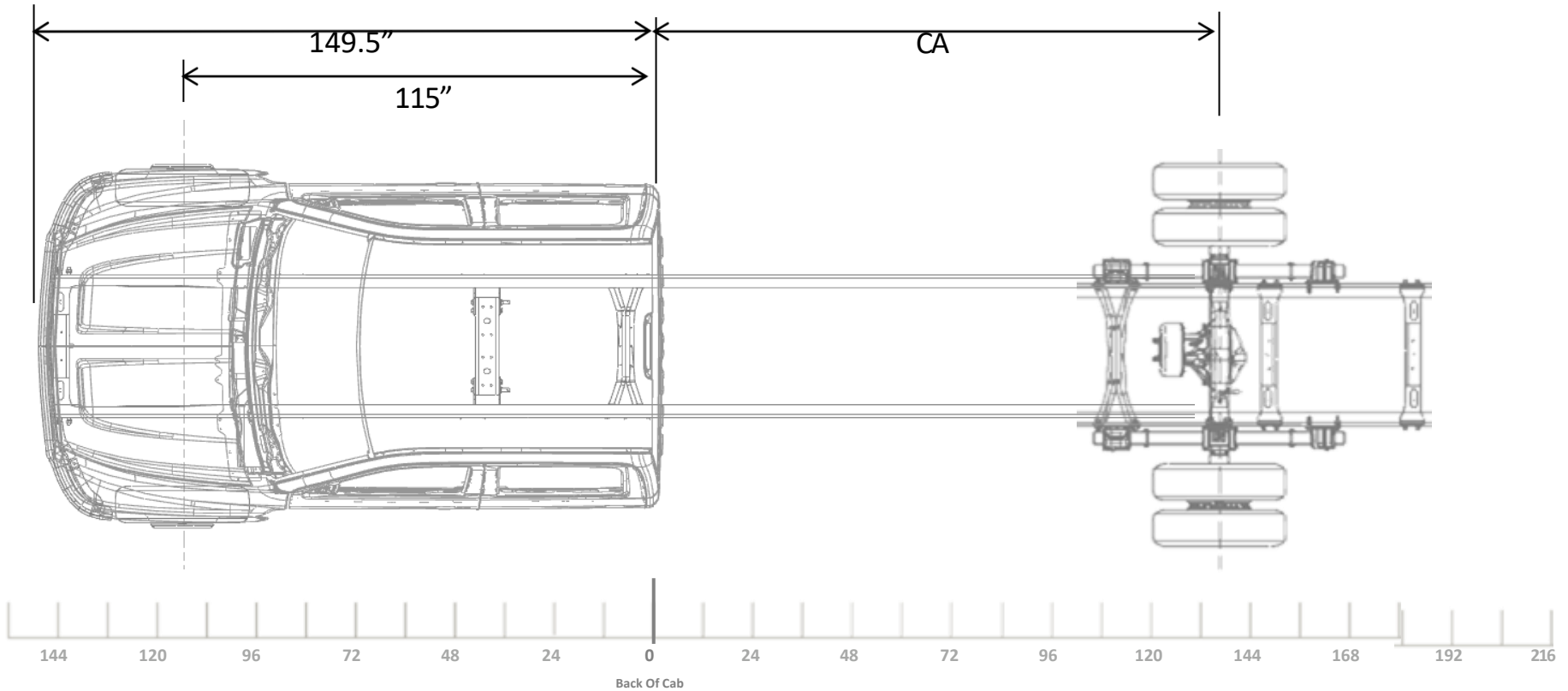

LAST REVISION: 9/28/2023

CREW CAB
175" WB

Model/Feature Information

Model:		C56043 K56043
Cab:		CREW CAB
Aftertreatment:		HORIZONTAL
Fuel Tank:	RPO N2L	40 GAL, AF MTD
Battery Box:	RPO 7Y7/7Y8	28" STEEL, 2 BATTERIES
Air Tanks:		(1) OUTSIDE LEFT
DEF Tank:		6.75 GAL
Engine:		6.6L GM DURAMAX

General Configuration Information

4X2 OR 4X4 TRUCK CONFIGURATION
VARI-RATE REAR SUSPENSION
RT SIDE TAILPIPE, EXIT BEHIND REAR WHEEL (RPO NPR)
OPTIONAL AIR DRYER FWD OUTSIDE RT (RPO KUT/JPY)

Minimum Wheelbase

175" WB (60" CA)
49" AF

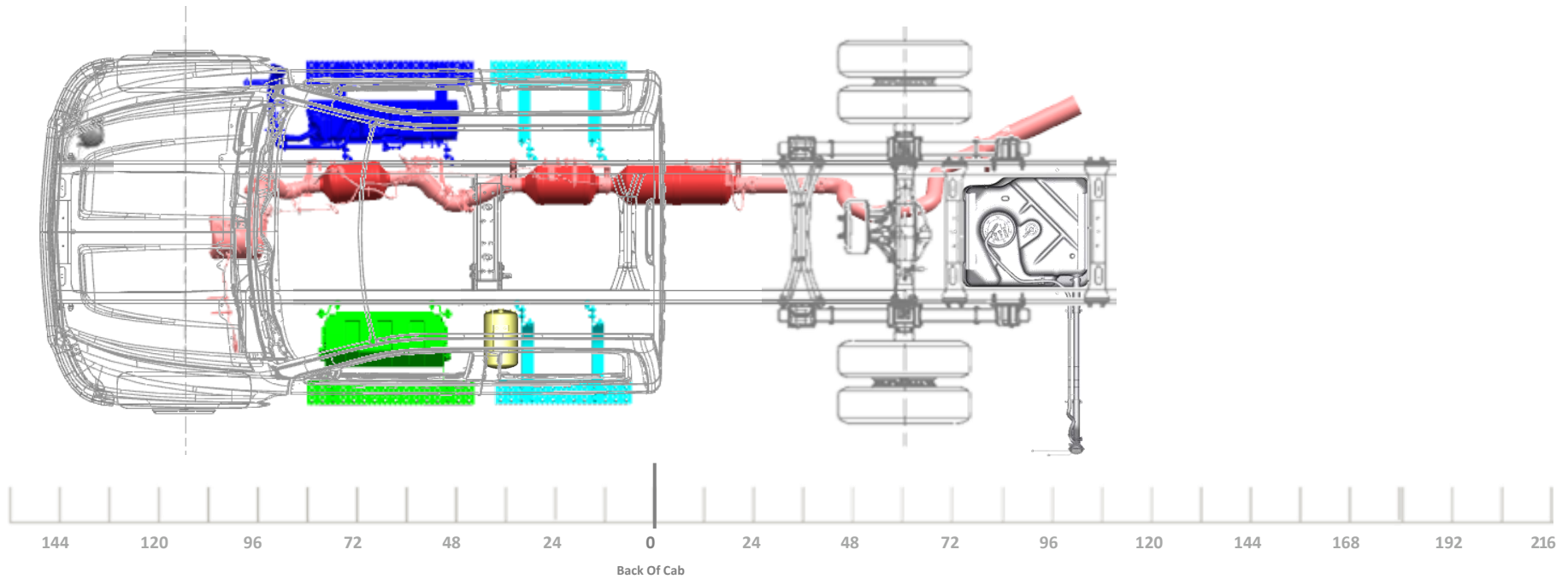

LAST REVISION: 9/28/2023

Model/Feature Information

Model:		C56043 K56043
Cab:		CREW CAB
Aftertreatment:		HORIZONTAL
Fuel Tank:	RPO N2L	40 GAL, AF MTD
Battery Box:	RPO 7Y9	TEMP MTD, 3 BATT
Air Tanks:		(1) OUTSIDE LEFT
DEF Tank:		6.75 GAL
Engine:		6.6L GM DURAMAX

General Configuration Information

4X2 OR 4X4 TRUCK CONFIGURATION
 VARI-RATE REAR SUSPENSION

RT SIDE TAILPIPE, EXIT BEHIND REAR
 WHEEL (RPO NPR)

OPTIONAL AIR DRYER FWD OUTSIDE
 RT (RPO KUT/JPY)

Minimum Wheelbase

175" WB (60" CA)
 49" AF

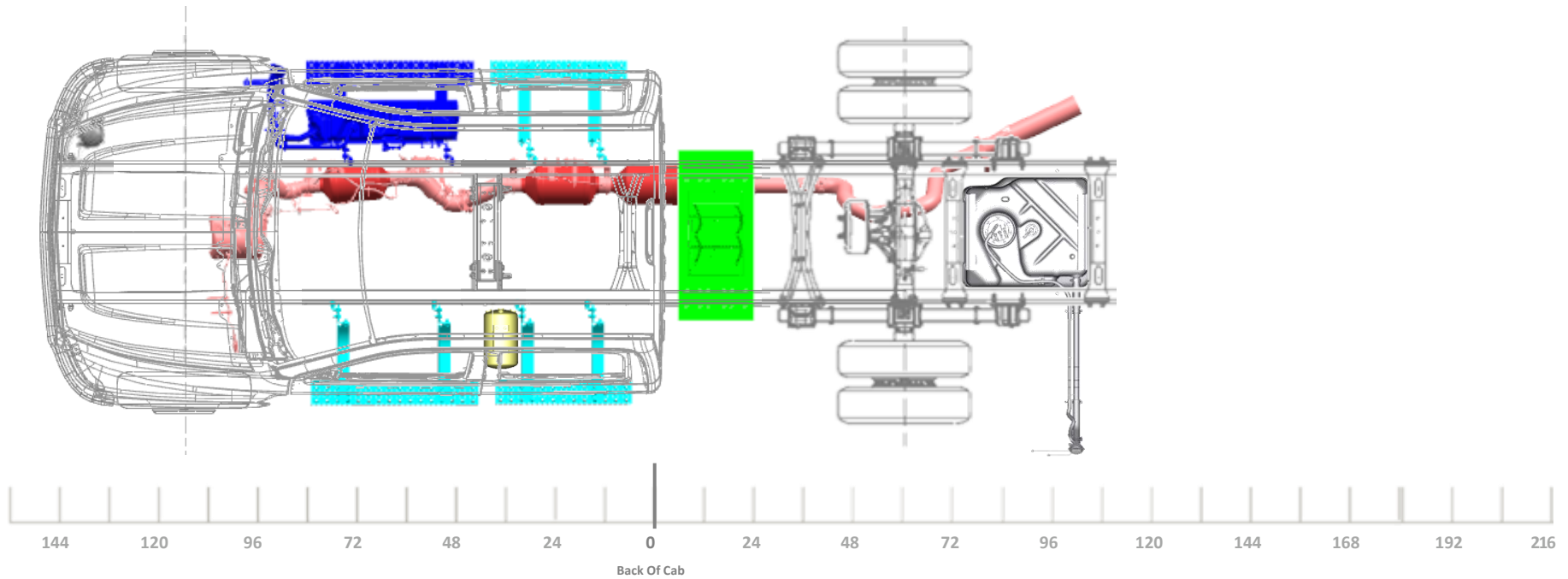

LAST REVISION: 9/28/2023

Model/Feature Information

Model:		C56043 K56043
Cab:		CREW CAB
Aftertreatment:		HORIZONTAL
Fuel Tank:	RPO N2L	40 GAL, AF MTD
Battery Box:	RPO 7Y7/7Y8	28" STEEL, 2 BATTERIES
Air Tanks:		(1) OUTSIDE LEFT
DEF Tank:		6.75 GAL
Engine:		6.6L GM DURAMAX

General Configuration Information

4X2 OR 4X4 TRUCK CONFIGURATION
 VARI-RATE REAR SUSPENSION

SIDE EXIT TAILPIPE AHEAD OF REAR
 WHEELS, LT SIDE (RPO NPJ)

OPTIONAL AIR DRYER FWD OUTSIDE
 RT (RPO KUT/JPY)

Minimum Wheelbase

175" WB (60" CA)
 49" AF

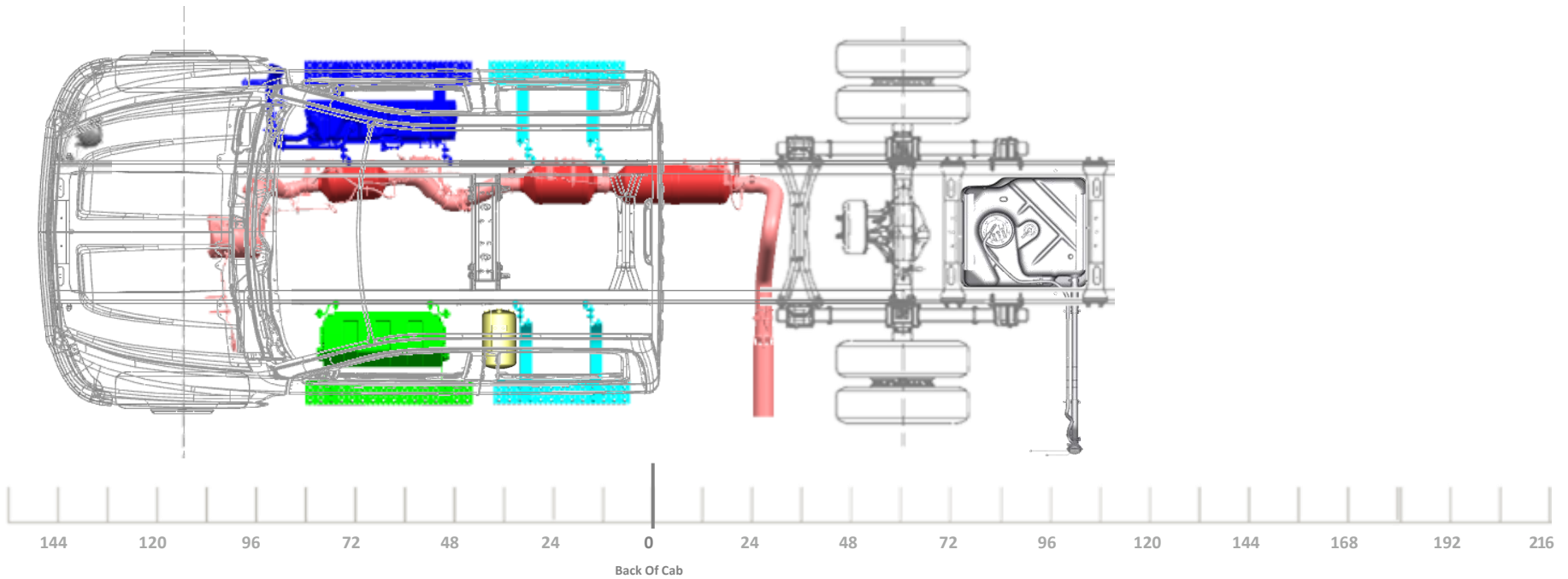

LAST REVISION: 9/28/2023

Model/Feature Information

Model:		C56043 K56043
Cab:		CREW CAB
Aftertreatment:		HORIZONTAL
Fuel Tank:	RPO N2L	40 GAL, AF MTD
Battery Box:	RPO 7Y9	TEMP MTD, 3 BATT
Air Tanks:		(1) OUTSIDE LEFT
DEF Tank:		6.75 GAL
Engine:		6.6L GM DURAMAX

General Configuration Information

4X2 OR 4X4 TRUCK CONFIGURATION
 VARI-RATE REAR SUSPENSION

SIDE EXIT TAILPIPE AHEAD OF REAR
 WHEELS, LT SIDE (RPO NPJ)

OPTIONAL AIR DRYER FWD OUTSIDE
 RT (RPO KUT/JPY)

Minimum Wheelbase

175" WB (60" CA)
 49" AF

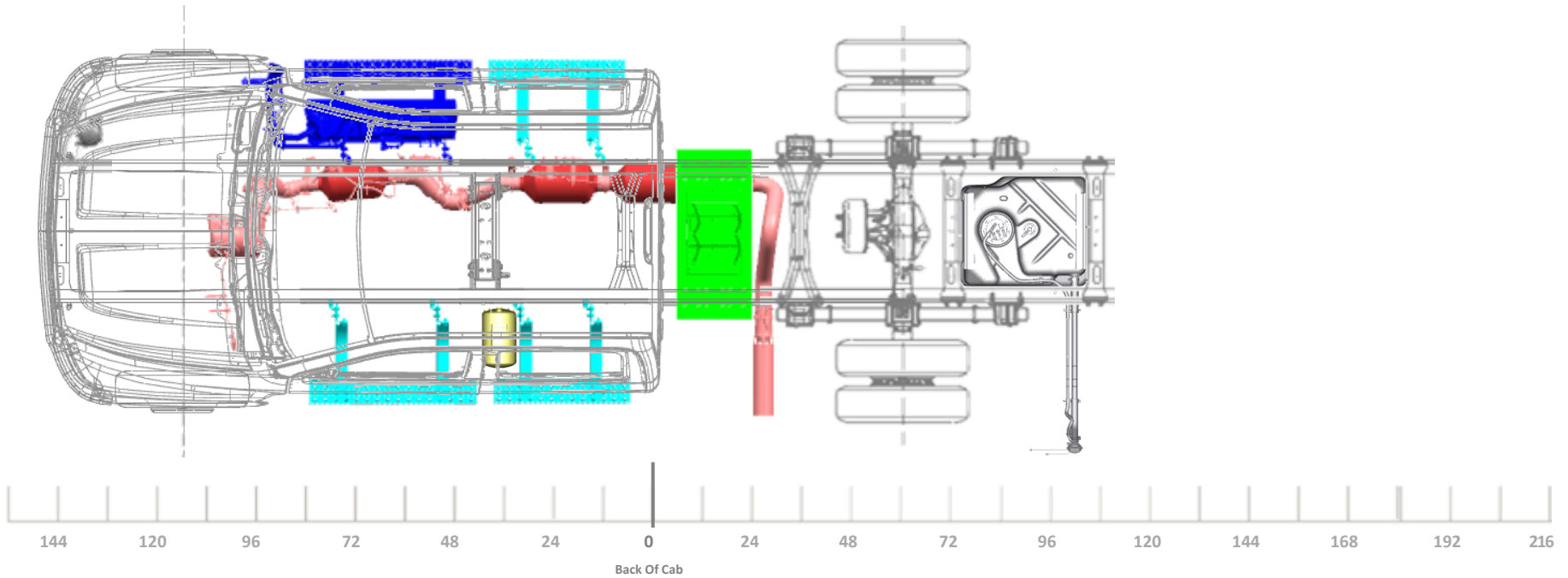

LAST REVISION: 9/28/2023

Model/Feature Information

Model:		C56043 K56043
Cab:		CREW CAB
Aftertreatment:		HORIZONTAL
Fuel Tank:	RPO NVK	25 GAL, CA MTD
Battery Box:	RPO 7Y7/7Y8	28" STEEL, 2 BATTERIES
Air Tanks:		(1) OUTSIDE LEFT
DEF Tank:		6.75 GAL
Engine:		6.6L GM DURAMAX

General Configuration Information

4X2 OR 4X4 TRUCK CONFIGURATION
 VARI-RATE REAR SUSPENSION
 RT SIDE TAILPIPE, EXIT BEHIND REAR WHEEL (RPO NPR)
 OPTIONAL AIR DRYER FWD OUTSIDE RT (RPO KUT/JPY)

Minimum Wheelbase

175" WB (60" CA)
 49" AF

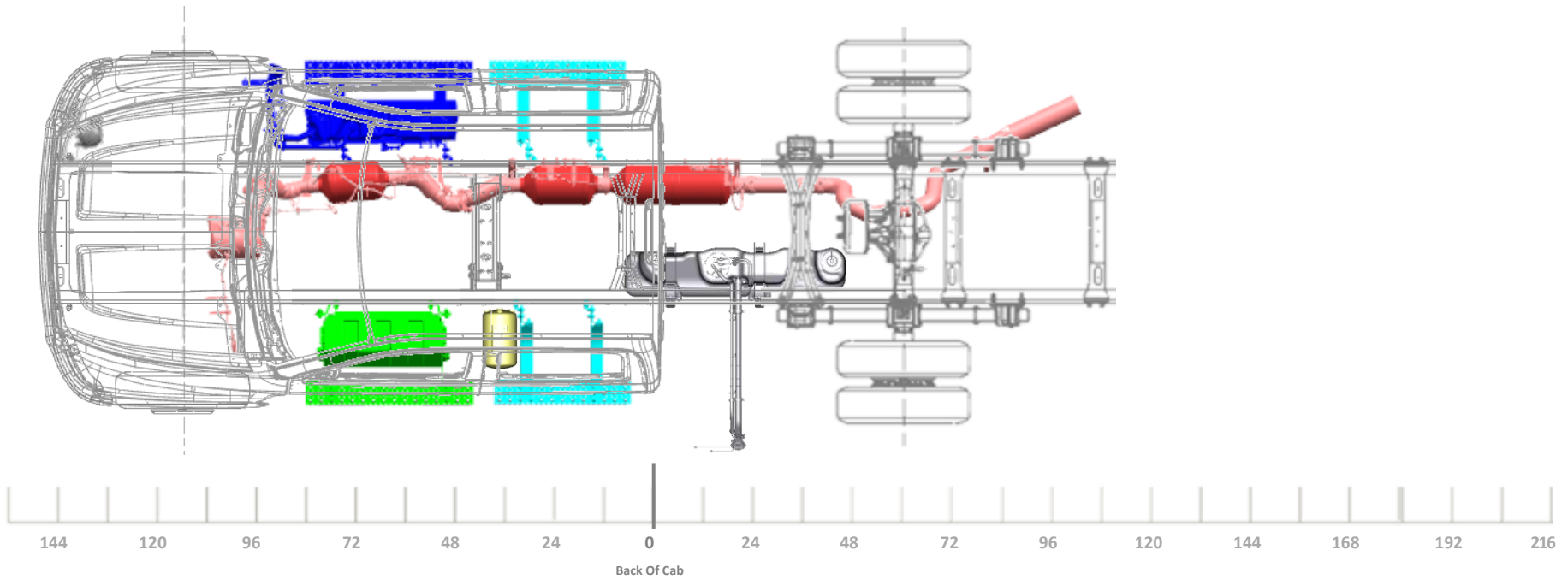

LAST REVISION: 9/28/2023

Model/Feature Information

Model:		C56043 K56043
Cab:		CREW CAB
Aftertreatment:		HORIZONTAL
Fuel Tank:	RPO NSQ	DUAL 25G CA, 40G AF
Battery Box:	RPO 7Y7/7Y8	28" STEEL, 2 BATTERIES
Air Tanks:		(1) OUTSIDE LEFT
DEF Tank:		6.75 GAL
Engine:		6.6L GM DURAMAX

General Configuration Information

4X2 OR 4X4 TRUCK CONFIGURATION
 VARI-RATE REAR SUSPENSION
 RT SIDE TAILPIPE, EXIT BEHIND REAR WHEEL (RPO NPR)
 OPTIONAL AIR DRYER FWD OUTSIDE RT (RPO KUT/JPY)

Minimum Wheelbase

175" WB (60" CA)
 49" AF

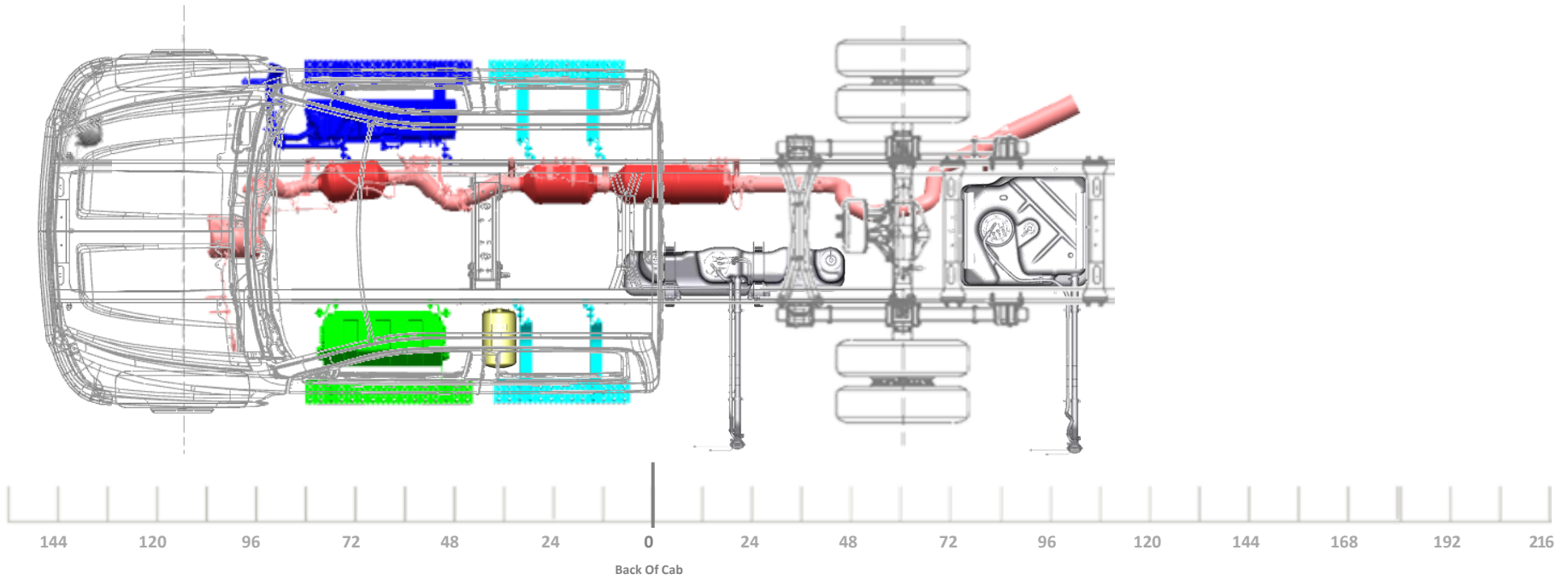

LAST REVISION: 9/28/2023

CREW CAB
199" WB

Model/Feature Information

Model:		C56043 K56043
Cab:		CREW CAB
Aftertreatment:		HORIZONTAL
Fuel Tank:	RPO N2L	40 GAL, AF MTD
Battery Box:	RPO 7Y7/7Y8	28" STEEL, 2 BATTERIES
Air Tanks:		(1) OUTSIDE LEFT
DEF Tank:		6.75 GAL
Engine:		6.6L GM DURAMAX

General Configuration Information

4X2 OR 4X4 TRUCK CONFIGURATION
VARI-RATE REAR SUSPENSION

STRAIGHT TAILPIPE (RPO N12)

OPTIONAL AIR DRYER FWD OUTSIDE
RT (RPO KUT/JPY)

Minimum Wheelbase

199" WB (84" CA)
49" OR 63" AF

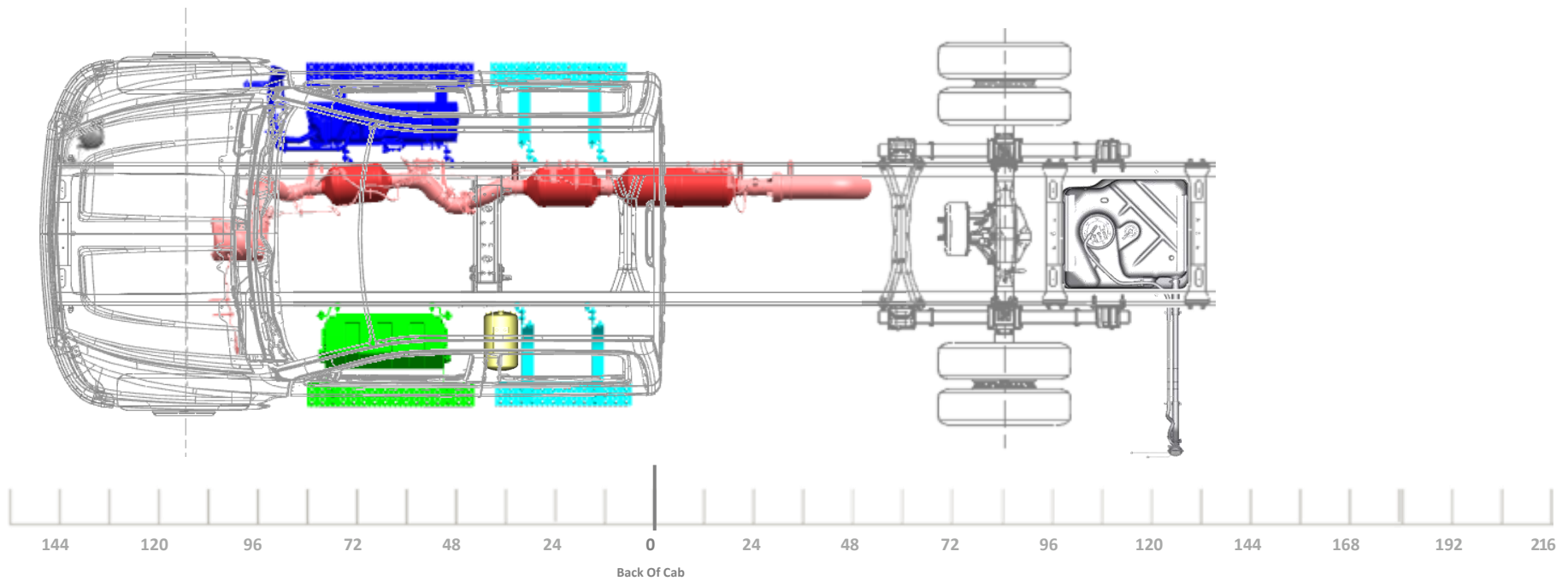

LAST REVISION: 9/28/2023

Model/Feature Information

Model:		C56043 K56043
Cab:		CREW CAB
Aftertreatment:		HORIZONTAL
Fuel Tank:	RPO N2L	40 GAL, AF MTD
Battery Box:	RPO 7Y7/7Y8	28" STEEL, 2 BATTERIES
Air Tanks:		(1) OUTSIDE LEFT
DEF Tank:		6.75 GAL
Engine:		6.6L GM DURAMAX

General Configuration Information

4X2 TRUCK CONFIGURATION
REAR AIR SUSPENSION
STRAIGHT TAILPIPE (RPO N12)
OPTIONAL AIR DRYER FWD OUTSIDE RT (RPO KUT/JPY)

Minimum Wheelbase

199" WB (84" CA)
63" AF

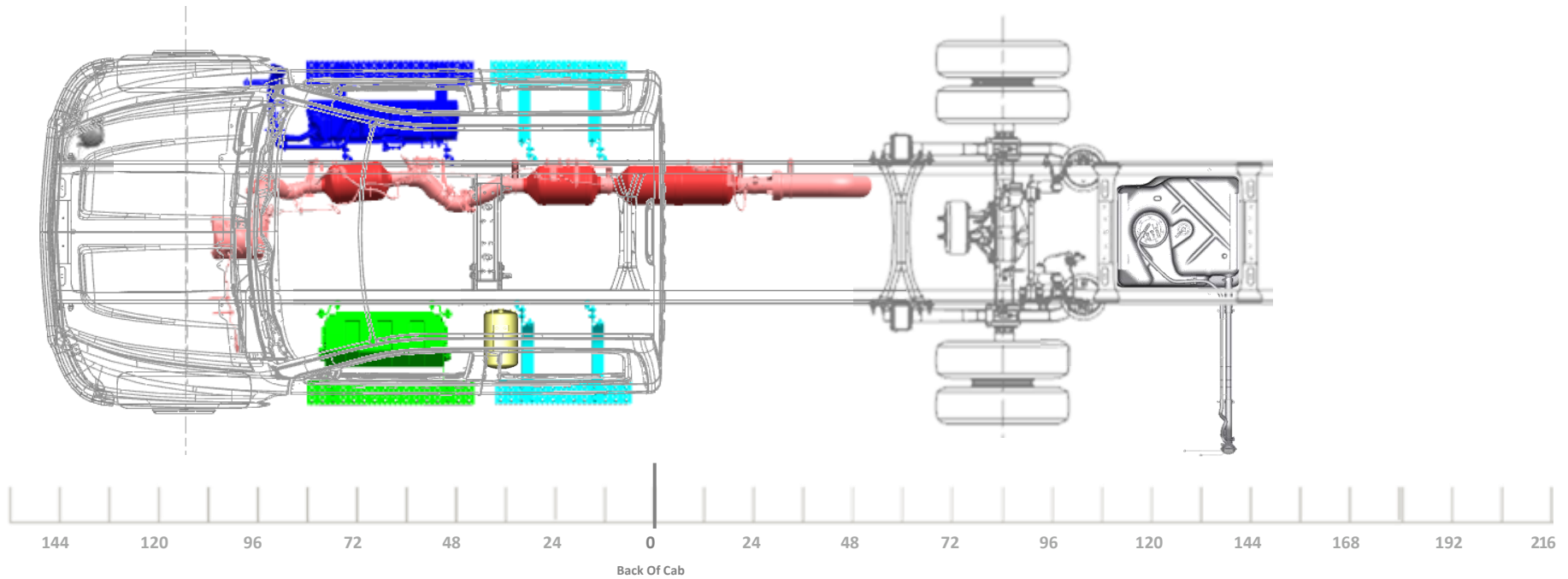

LAST REVISION: 9/28/2023

Model/Feature Information

Model:		C56043 K56043
Cab:		CREW CAB
Aftertreatment:		HORIZONTAL
Fuel Tank:	RPO N2L	40 GAL, AF MTD
Battery Box:	RPO 7Y9	TEMP MTD, 3 BATT
Air Tanks:		(1) OUTSIDE LEFT
DEF Tank:		6.75 GAL
Engine:		6.6L GM DURAMAX

General Configuration Information

4X2 OR 4X4 TRUCK CONFIGURATION
 VARI-RATE REAR SUSPENSION

STRAIGHT TAILPIPE (RPO N12)

OPTIONAL AIR DRYER FWD OUTSIDE
 RT (RPO KUT/JPY)

Minimum Wheelbase

199" WB (84" CA)
 49" OR 63" AF

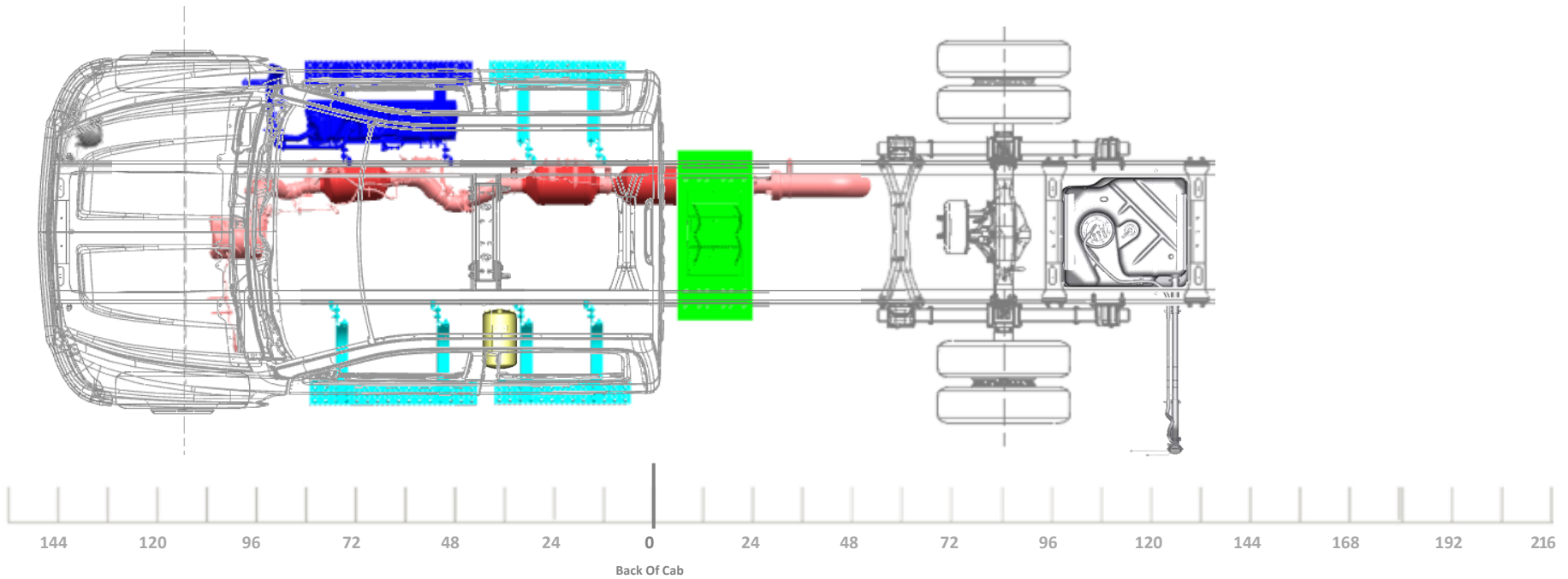

*LAST REVISION: 9/28/2023

Model/Feature Information

Model:		C56043 K56043
Cab:		CREW CAB
Aftertreatment:		HORIZONTAL
Fuel Tank:	RPO N2L	40 GAL, AF MTD
Battery Box:	RPO 7Y9	TEMP MTD, 3 BATT
Air Tanks:		(1) OUTSIDE LEFT
DEF Tank:		6.75 GAL
Engine:		6.6L GM DURAMAX

General Configuration Information

4X2 TRUCK CONFIGURATION
REAR AIR SUSPENSION
STRAIGHT TAILPIPE (RPO N12)
OPTIONAL AIR DRYER FWD OUTSIDE RT (RPO KUT/JPY)

Minimum Wheelbase

199" WB (84" CA)
63" AF

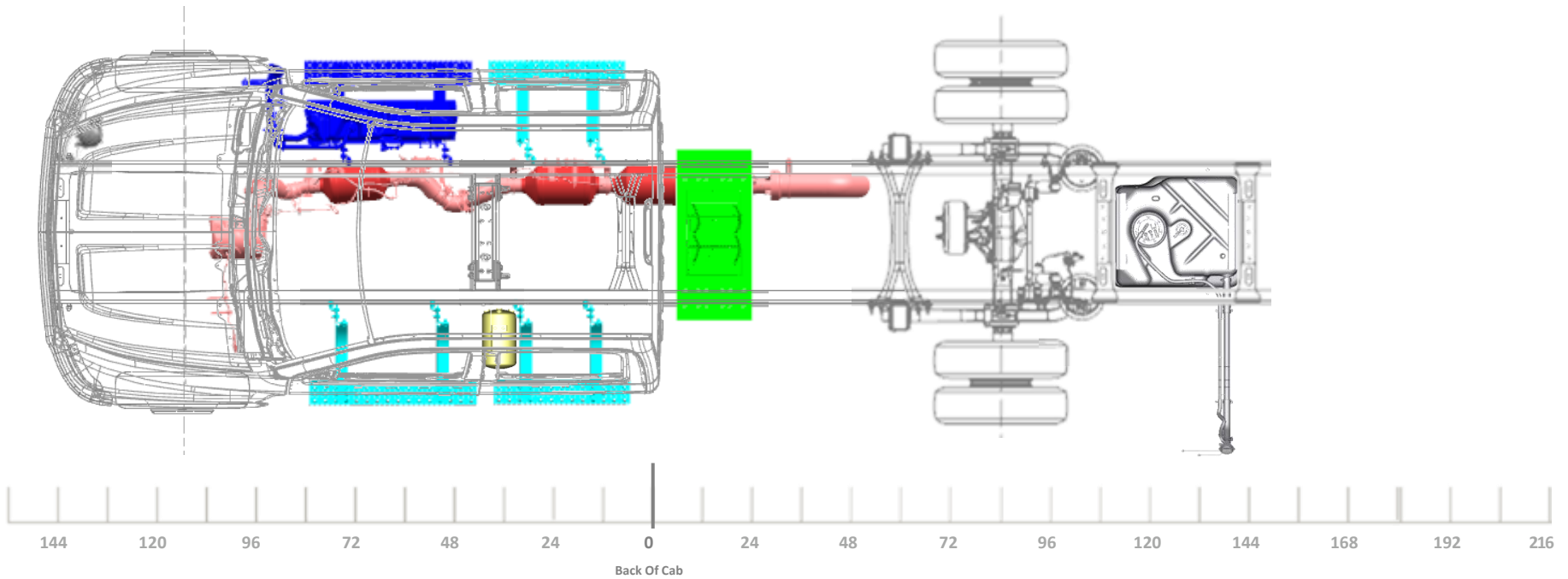

LAST REVISION: 9/28/2023

Model/Feature Information

Model:		C56043 K56043
Cab:		CREW CAB
Aftertreatment:		HORIZONTAL
Fuel Tank:	RPO N2L	40 GAL, AF MTD
Battery Box:	RPO 7Y7/7Y8	28" STEEL, 2 BATTERIES
Air Tanks:		(1) OUTSIDE LEFT
DEF Tank:		6.75 GAL
Engine:		6.6L GM DURAMAX

General Configuration Information

4X2 OR 4X4 TRUCK CONFIGURATION
 VARI-RATE REAR SUSPENSION

SIDE EXIT TAILPIPE AHEAD OF REAR
 WHEELS, LT SIDE (RPO NPJ)

OPTIONAL AIR DRYER FWD OUTSIDE
 RT (RPO KUT/JPY)

Minimum Wheelbase

199" WB (84" CA)
 49" OR 63" AF

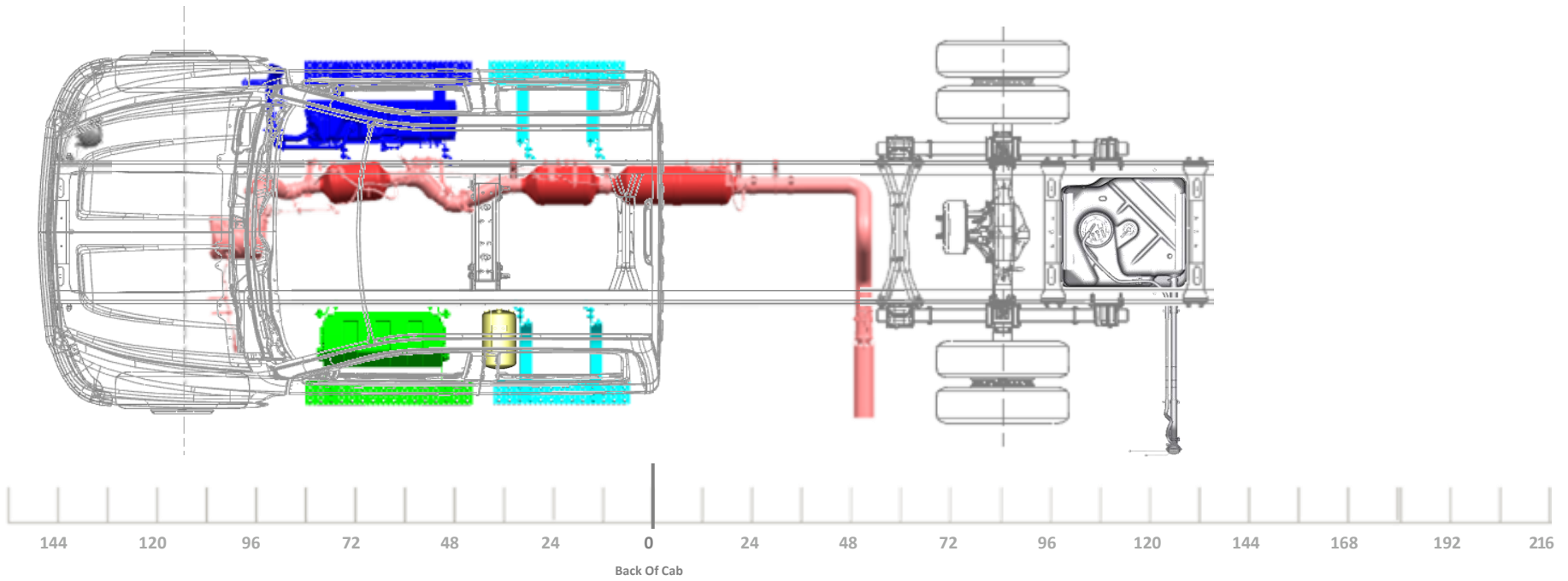

LAST REVISION: 9/28/2023

Model/Feature Information

Model:		C56043 K56043
Cab:		CREW CAB
Aftertreatment:		HORIZONTAL
Fuel Tank:	RPO N2L	40 GAL, AF MTD
Battery Box:	RPO 7Y7/7Y8	28" STEEL, 2 BATTERIES
Air Tanks:		(1) OUTSIDE LEFT
DEF Tank:		6.75 GAL
Engine:		6.6L GM DURAMAX

General Configuration Information

4X2 TRUCK CONFIGURATION
REAR AIR SUSPENSION
SIDE EXIT TAILPIPE AHEAD OF REAR WHEELS, LT SIDE (RPO NPJ)
OPTIONAL AIR DRYER FWD OUTSIDE RT (RPO KUT/JPY)

Minimum Wheelbase

199" WB (84" CA)
63" AF

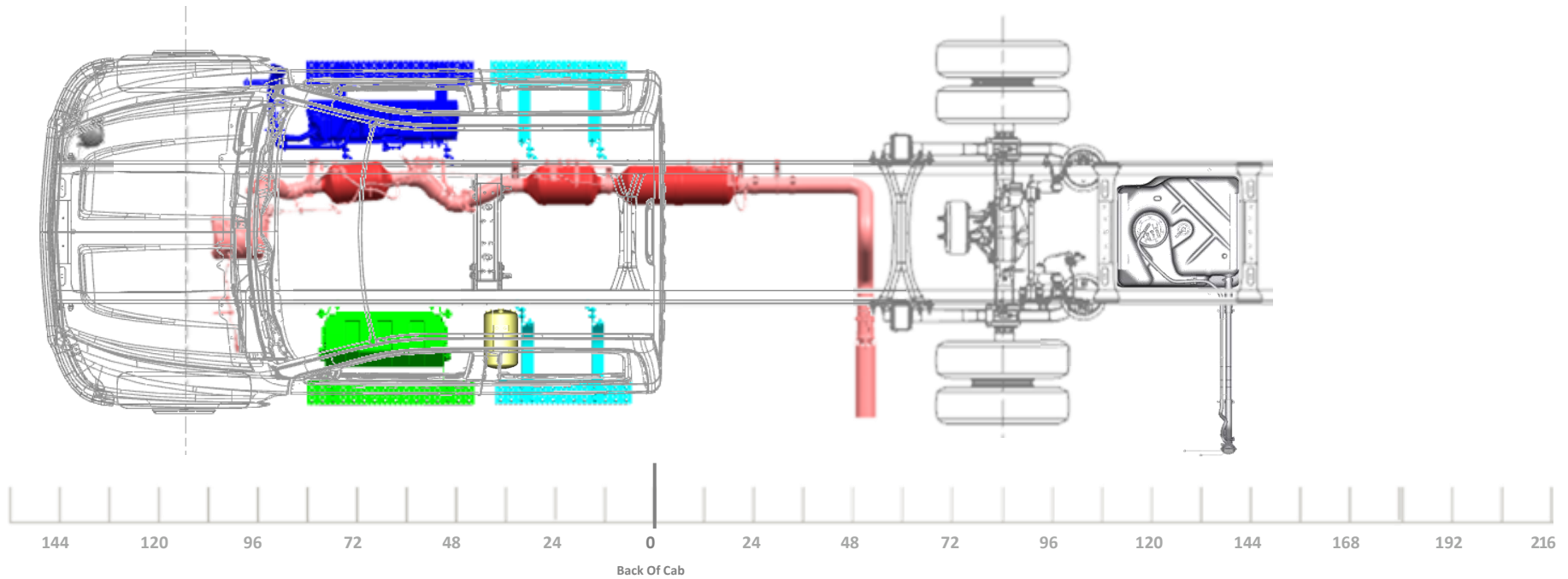

LAST REVISION: 9/28/2023

Model/Feature Information

Model:		C56043 K56043
Cab:		CREW CAB
Aftertreatment:		HORIZONTAL
Fuel Tank:	RPO N2L	40 GAL, AF MTD
Battery Box:	RPO 7Y9	TEMP MTD, 3 BATT
Air Tanks:		(1) OUTSIDE LEFT
DEF Tank:		6.75 GAL
Engine:		6.6L GM DURAMAX

General Configuration Information

4X2 OR 4X4 TRUCK CONFIGURATION
 VARI-RATE REAR SUSPENSION

SIDE EXIT TAILPIPE AHEAD OF REAR
 WHEELS, LT SIDE (RPO NPJ)

OPTIONAL AIR DRYER FWD OUTSIDE
 RT (RPO KUT/JPY)

Minimum Wheelbase

199" WB (84" CA)
 49" OR 63" AF

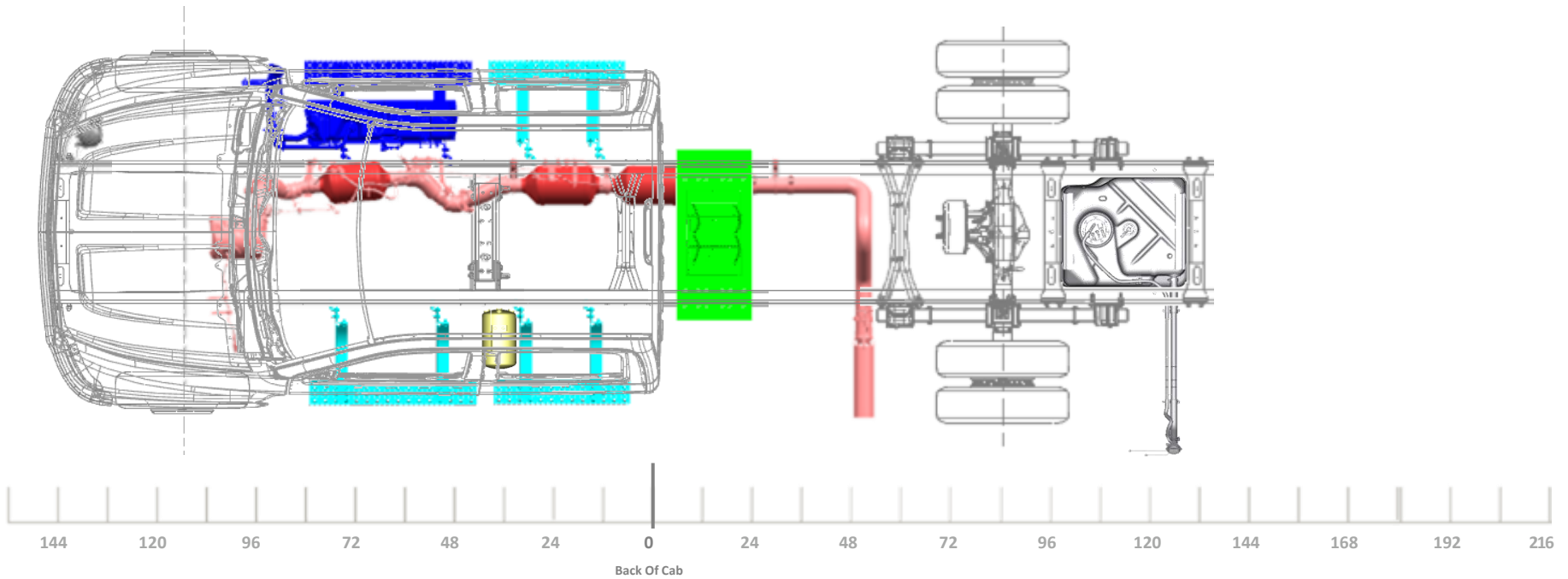

LAST REVISION: 9/28/2023

Model/Feature Information

Model:		C56043 K56043
Cab:		CREW CAB
Aftertreatment:		HORIZONTAL
Fuel Tank:	RPO N2L	40 GAL, AF MTD
Battery Box:	RPO 7Y9	TEMP MTD, 3 BATT
Air Tanks:		(1) OUTSIDE LEFT
DEF Tank:		6.75 GAL
Engine:		6.6L GM DURAMAX

General Configuration Information

4X2 TRUCK CONFIGURATION
 REAR AIR SUSPENSION
 SIDE EXIT TAILPIPE AHEAD OF REAR WHEELS, LT SIDE (RPO NPJ)
 OPTIONAL AIR DRYER FWD OUTSIDE RT (RPO KUT/JPY)

Minimum Wheelbase

199" WB (84" CA)
 63" AF

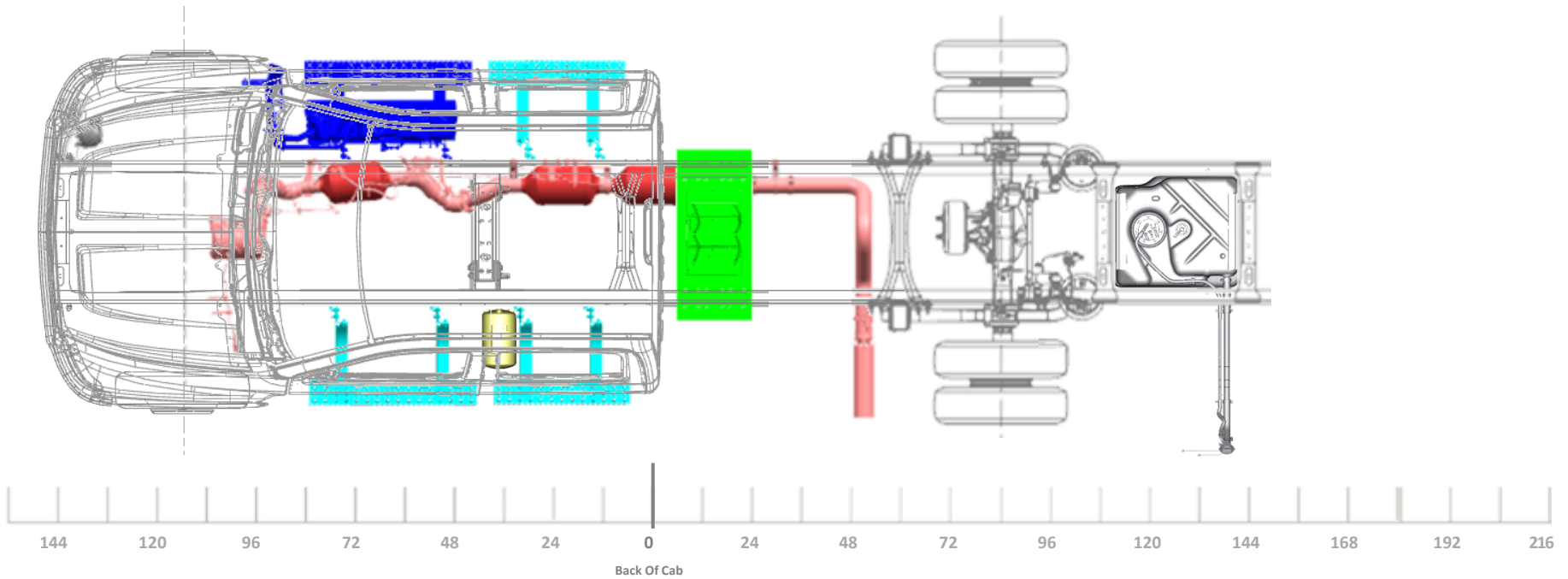

LAST REVISION: 9/28/2023

Model/Feature Information

Model:		C56043 K56043
Cab:		CREW CAB
Aftertreatment:		HORIZONTAL
Fuel Tank:	RPO N2L	40 GAL, AF MTD
Battery Box:	RPO 7Y7/7Y8	28" STEEL, 2 BATTERIES
Air Tanks:		(1) OUTSIDE LEFT
DEF Tank:		6.75 GAL
Engine:		6.6L GM DURAMAX

General Configuration Information

4X2 OR 4X4 TRUCK CONFIGURATION
 VARI-RATE REAR SUSPENSION

SIDE EXIT TAILPIPE AHEAD OF REAR
 WHEELS, RT SIDE (RPO NPK)

OPTIONAL AIR DRYER FWD OUTSIDE
 RT (RPO KUT/JPY)

Minimum Wheelbase

199" WB (84" CA)
 49" OR 63" AF

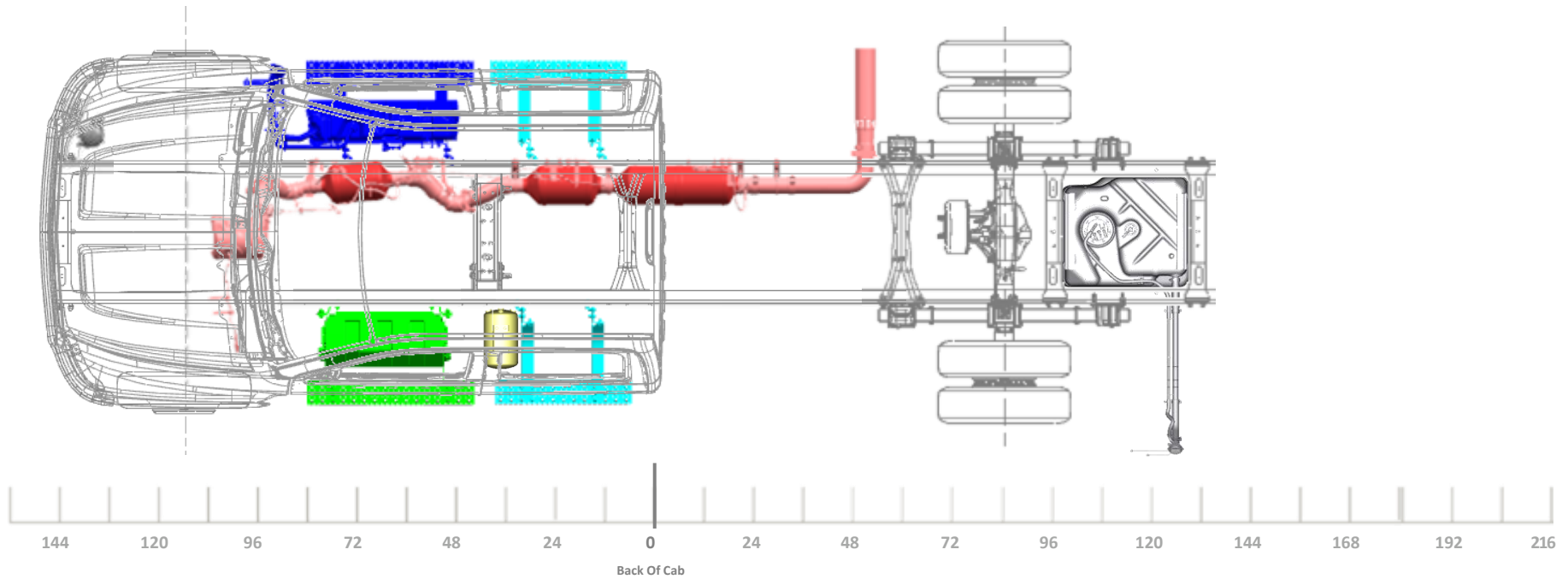

LAST REVISION: 9/28/2023

Model/Feature Information

Model:		C56043 K56043
Cab:		CREW CAB
Aftertreatment:		HORIZONTAL
Fuel Tank:	RPO N2L	40 GAL, AF MTD
Battery Box:	RPO 7Y7/7Y8	28" STEEL, 2 BATTERIES
Air Tanks:		(1) OUTSIDE LEFT
DEF Tank:		6.75 GAL
Engine:		6.6L GM DURAMAX

General Configuration Information

4X2 TRUCK CONFIGURATION
 REAR AIR SUSPENSION
 SIDE EXIT TAILPIPE AHEAD OF REAR WHEELS, RT SIDE (RPO NPK)
 OPTIONAL AIR DRYER FWD OUTSIDE RT (RPO KUT/JPY)

Minimum Wheelbase

199" WB (84" CA)
 63" AF

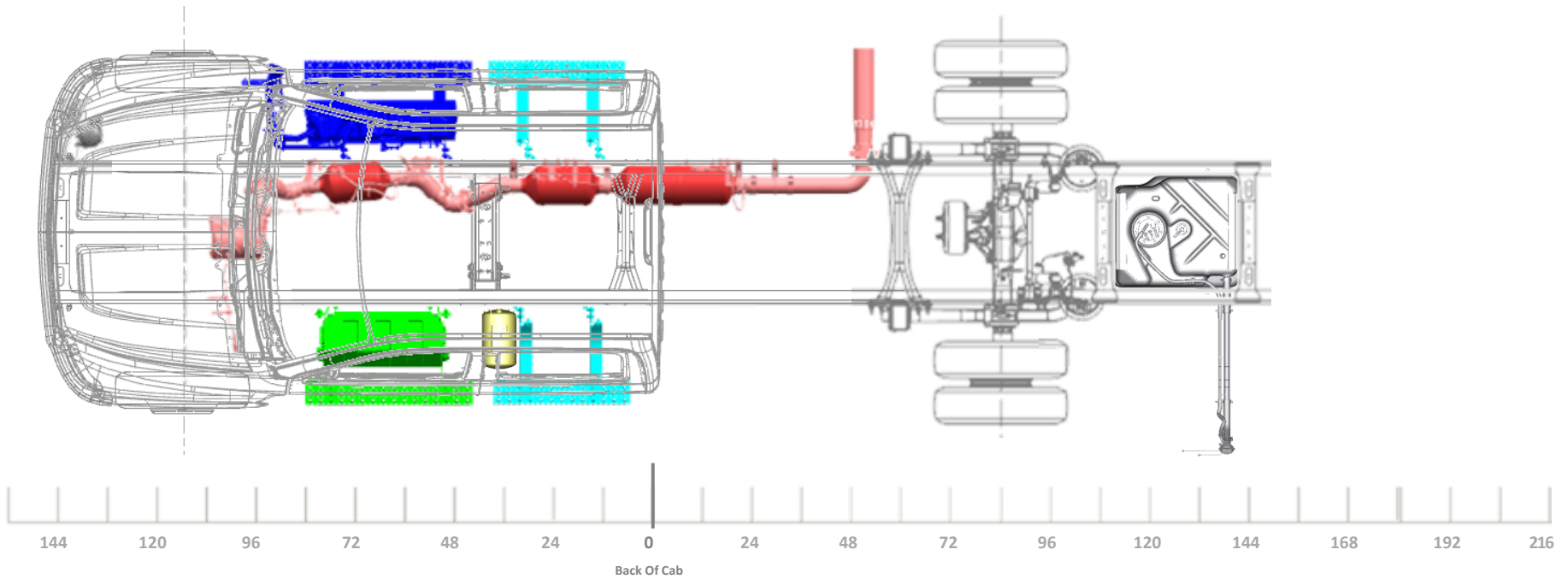

LAST REVISION: 9/28/2023

Model/Feature Information

Model:		C56043 K56043
Cab:		CREW CAB
Aftertreatment:		HORIZONTAL
Fuel Tank:	RPO N2L	40 GAL, AF MTD
Battery Box:	RPO 7Y9	TEMP MTD, 3 BATT
Air Tanks:		(1) OUTSIDE LEFT
DEF Tank:		6.75 GAL
Engine:		6.6L GM DURAMAX

General Configuration Information

4X2 OR 4X4 TRUCK CONFIGURATION
 VARI-RATE REAR SUSPENSION
 SIDE EXIT TAILPIPE AHEAD OF REAR
 WHEELS, RT SIDE (RPO NPK)
 OPTIONAL AIR DRYER FWD OUTSIDE
 RT (RPO KUT/JPY)

Minimum Wheelbase

199" WB (84" CA)
 49" OR 63" AF

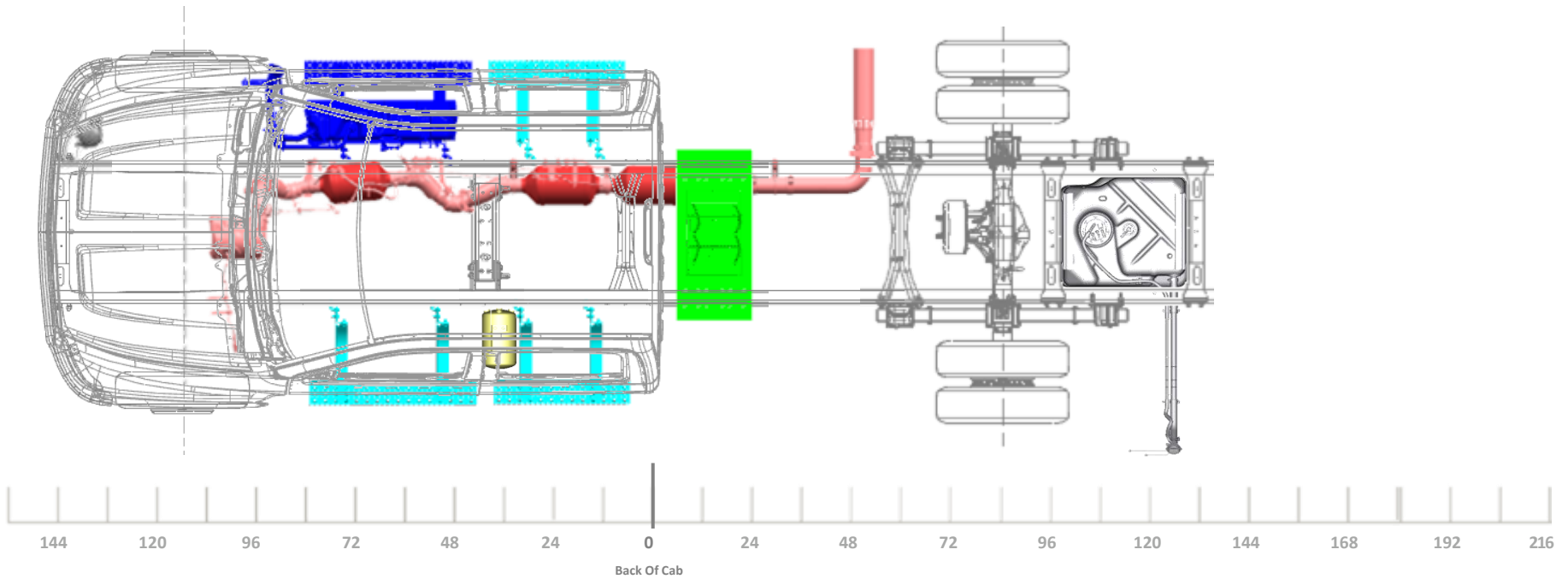

*LAST REVISION: 9/28/2023

Model/Feature Information

Model:		C56043 K56043
Cab:		CREW CAB
Aftertreatment:		HORIZONTAL
Fuel Tank:	RPO N2L	40 GAL, AF MTD
Battery Box:	RPO 7Y9	TEMP MTD, 3 BATT
Air Tanks:		(1) OUTSIDE LEFT
DEF Tank:		6.75 GAL
Engine:		6.6L GM DURAMAX

General Configuration Information

4X2 TRUCK CONFIGURATION
REAR AIR SUSPENSION
SIDE EXIT TAILPIPE AHEAD OF REAR WHEELS, RT SIDE (RPO NPK)
OPTIONAL AIR DRYER FWD OUTSIDE RT (RPO KUT/JPY)

Minimum Wheelbase

199" WB (84" CA)
63" AF

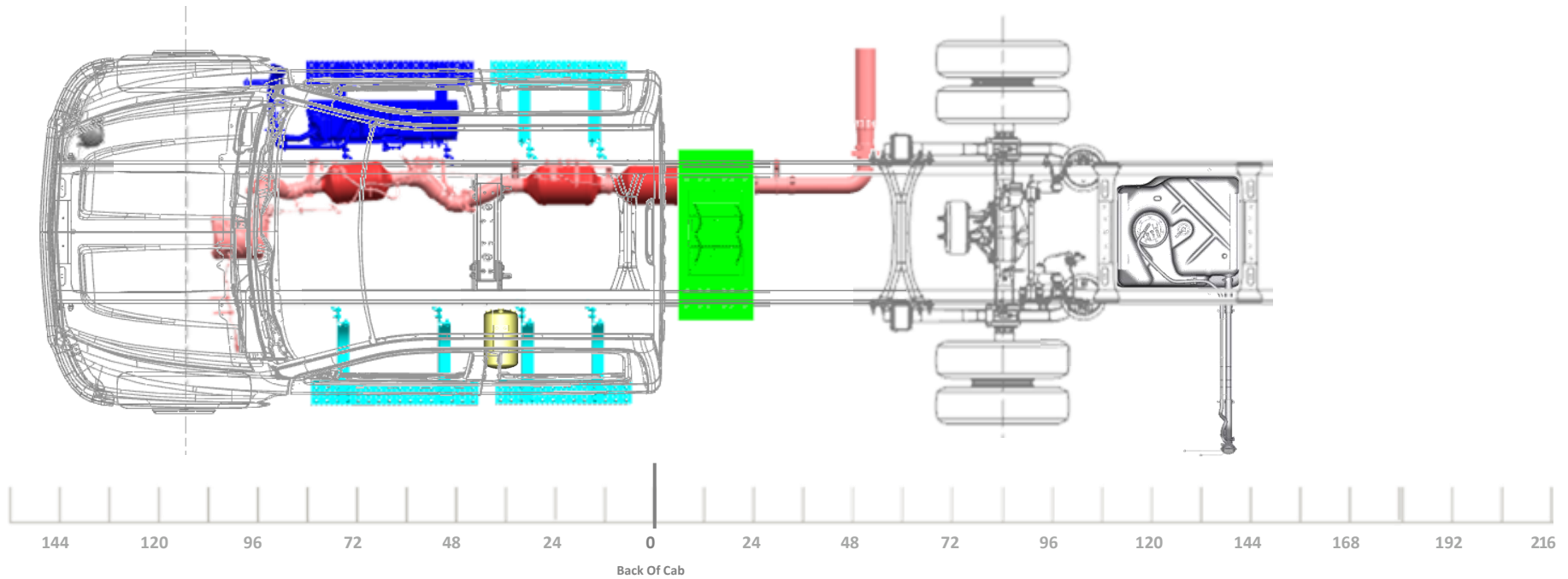

LAST REVISION: 9/28/2023

Model/Feature Information

Model:		C56043 K56043
Cab:		CREW CAB
Aftertreatment:		HORIZONTAL
Fuel Tank:	RPO NVK	25 GAL, CA MTD
Battery Box:	RPO 7Y7/7Y8	28" STEEL, 2 BATTERIES
Air Tanks:		(1) OUTSIDE LEFT
DEF Tank:		6.75 GAL
Engine:		6.6L GM DURAMAX

General Configuration Information

4X2 OR 4X4 TRUCK CONFIGURATION
 VARI-RATE REAR SUSPENSION

STRAIGHT TAILPIPE (RPO N12)

OPTIONAL AIR DRYER FWD OUTSIDE
 RT (RPO KUT/JPY)

Minimum Wheelbase

199" WB (84" CA)
 49" OR 63" AF

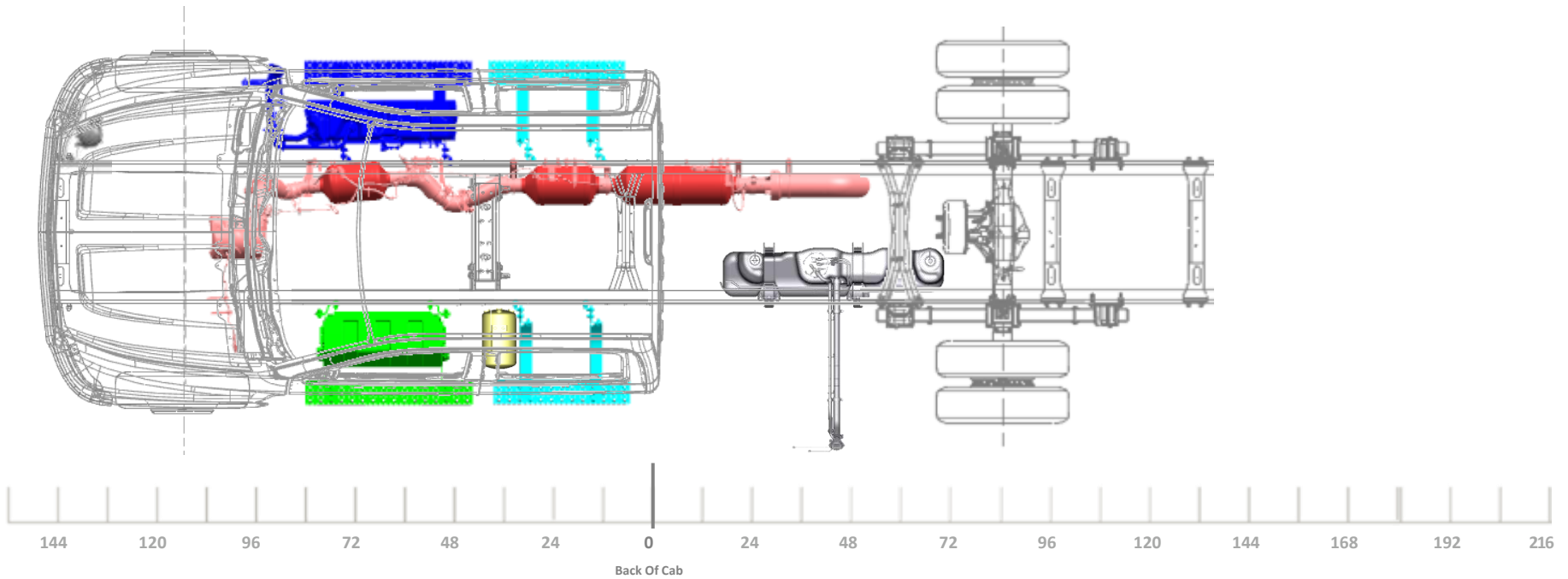

LAST REVISION: 9/28/2023

Model/Feature Information

Model:		C56043 K56043
Cab:		CREW CAB
Aftertreatment:		HORIZONTAL
Fuel Tank:	RPO NVK	25 GAL, CA MTD
Battery Box:	RPO 7Y7/7Y8	28" STEEL, 2 BATTERIES
Air Tanks:		(1) OUTSIDE LEFT
DEF Tank:		6.75 GAL
Engine:		6.6L GM DURAMAX

General Configuration Information

4X2 TRUCK CONFIGURATION
REAR AIR SUSPENSION
STRAIGHT TAILPIPE (RPO N12)
OPTIONAL AIR DRYER FWD OUTSIDE RT (RPO KUT/JPY)

Minimum Wheelbase

199" WB (84" CA)
63" AF

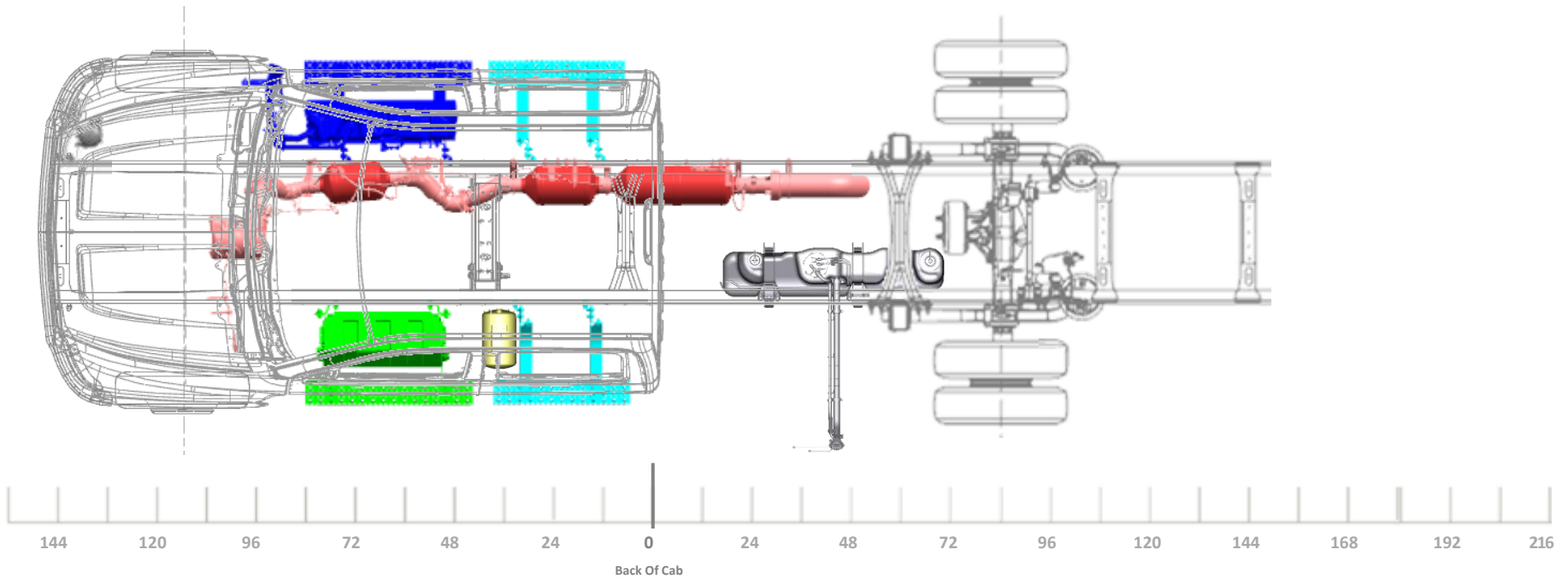

LAST REVISION: 9/28/2023

Model/Feature Information

Model:		C56043 K56043
Cab:		CREW CAB
Aftertreatment:		HORIZONTAL
Fuel Tank:	RPO NVK	25 GAL, CA MTD
Battery Box:	RPO 7Y9	TEMP MTD, 3 BATT
Air Tanks:		(1) OUTSIDE LEFT
DEF Tank:		6.75 GAL
Engine:		6.6L GM DURAMAX

General Configuration Information

4X2 OR 4X4 TRUCK CONFIGURATION
 VARI-RATE REAR SUSPENSION

STRAIGHT TAILPIPE (RPO N12)

OPTIONAL AIR DRYER FWD OUTSIDE
 RT (RPO KUT/JPY)

Minimum Wheelbase

199" WB (84" CA)
 49" OR 63" AF

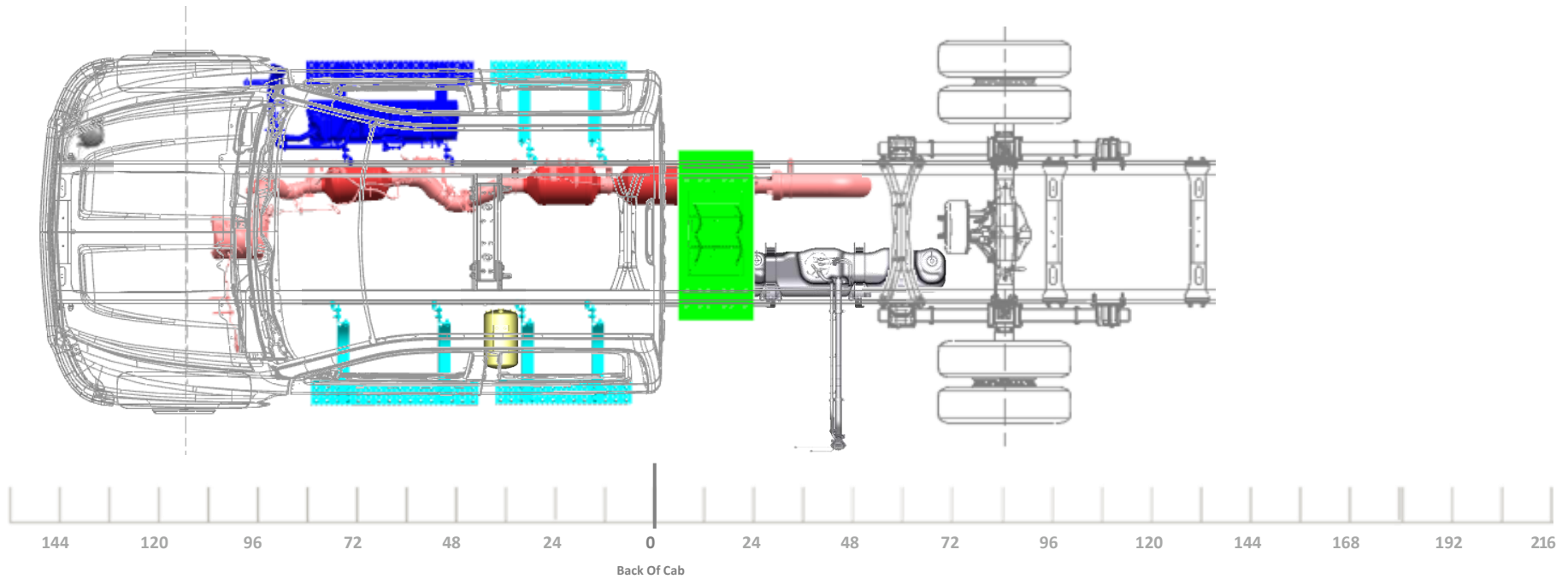

LAST REVISION: 9/28/2023

Model/Feature Information

Model:		C56043 K56043
Cab:		CREW CAB
Aftertreatment:		HORIZONTAL
Fuel Tank:	RPO NVK	25 GAL, CA MTD
Battery Box:	RPO 7Y9	TEMP MTD, 3 BATT
Air Tanks:		(1) OUTSIDE LEFT
DEF Tank:		6.75 GAL
Engine:		6.6L GM DURAMAX

General Configuration Information

4X2 TRUCK CONFIGURATION
REAR AIR SUSPENSION
STRAIGHT TAILPIPE (RPO N12)
OPTIONAL AIR DRYER FWD OUTSIDE RT (RPO KUT/JPY)

Minimum Wheelbase

199" WB (84" CA)
63" AF

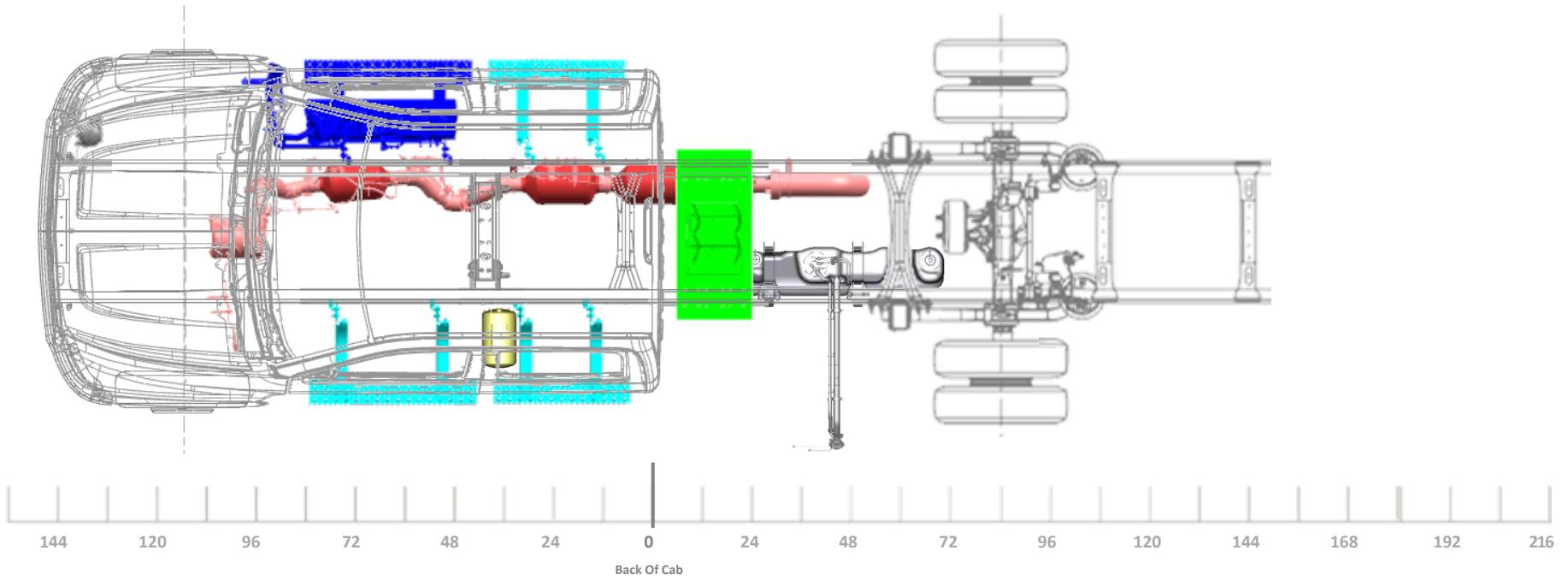

LAST REVISION: 9/28/2023

Model/Feature Information

Model:		C56043 K56043
Cab:		CREW CAB
Aftertreatment:		HORIZONTAL
Fuel Tank:	RPO NVK	25 GAL, CA MTD
Battery Box:	RPO 7Y7/7Y8	28" STEEL, 2 BATTERIES
Air Tanks:		(1) OUTSIDE LEFT
DEF Tank:		6.75 GAL
Engine:		6.6L GM DURAMAX

General Configuration Information

4X2 OR 4X4 TRUCK CONFIGURATION
VARI-RATE REAR SUSPENSION

SIDE EXIT TAILPIPE AHEAD OF REAR
WHEELS, RT SIDE (RPO NPK)

OPTIONAL AIR DRYER FWD OUTSIDE
RT (RPO KUT/JPY)

Minimum Wheelbase

199" WB (84" CA)
49" OR 63" AF

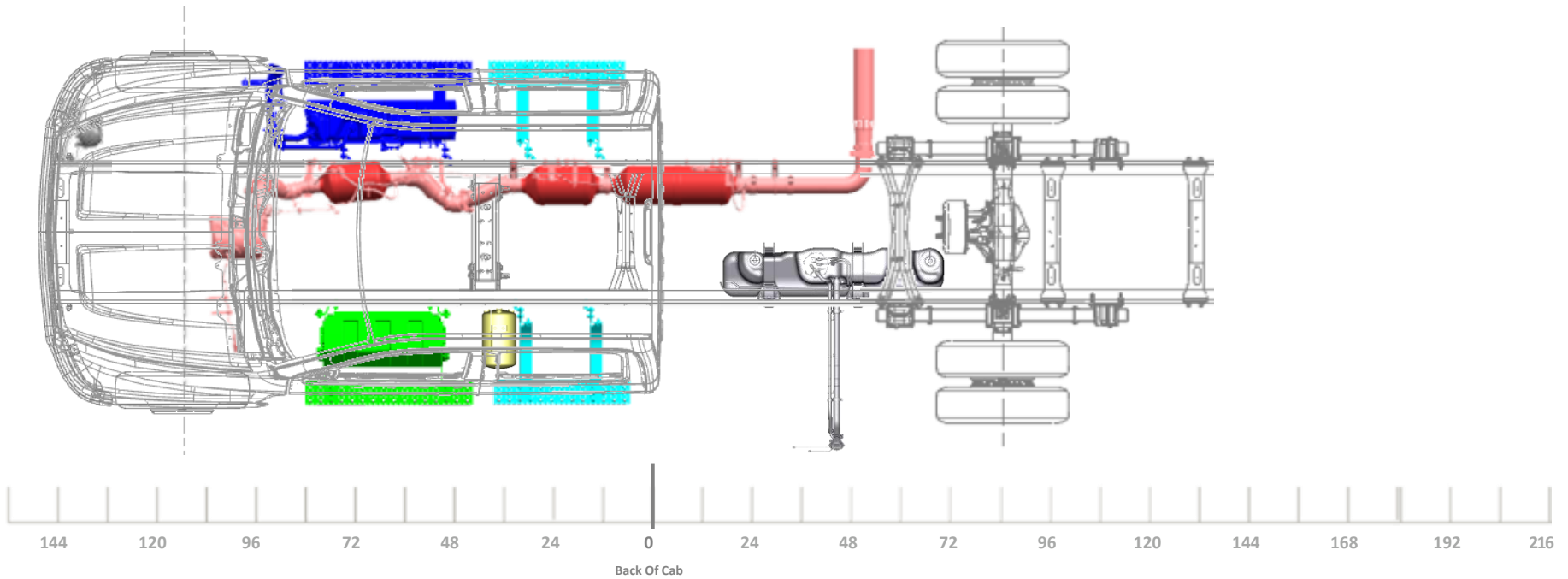

LAST REVISION: 9/28/2023

Model/Feature Information

Model:		C56043 K56043
Cab:		CREW CAB
Aftertreatment:		HORIZONTAL
Fuel Tank:	RPO NVK	25 GAL, CA MTD
Battery Box:	RPO 7Y7/7Y8	28" STEEL, 2 BATTERIES
Air Tanks:		(1) OUTSIDE LEFT
DEF Tank:		6.75 GAL
Engine:		6.6L GM DURAMAX

General Configuration Information

4X2 TRUCK CONFIGURATION
REAR AIR SUSPENSION
SIDE EXIT TAILPIPE AHEAD OF REAR WHEELS, RT SIDE (RPO NPK)
OPTIONAL AIR DRYER FWD OUTSIDE RT (RPO KUT/JPY)

Minimum Wheelbase

199" WB (84" CA)
63" AF

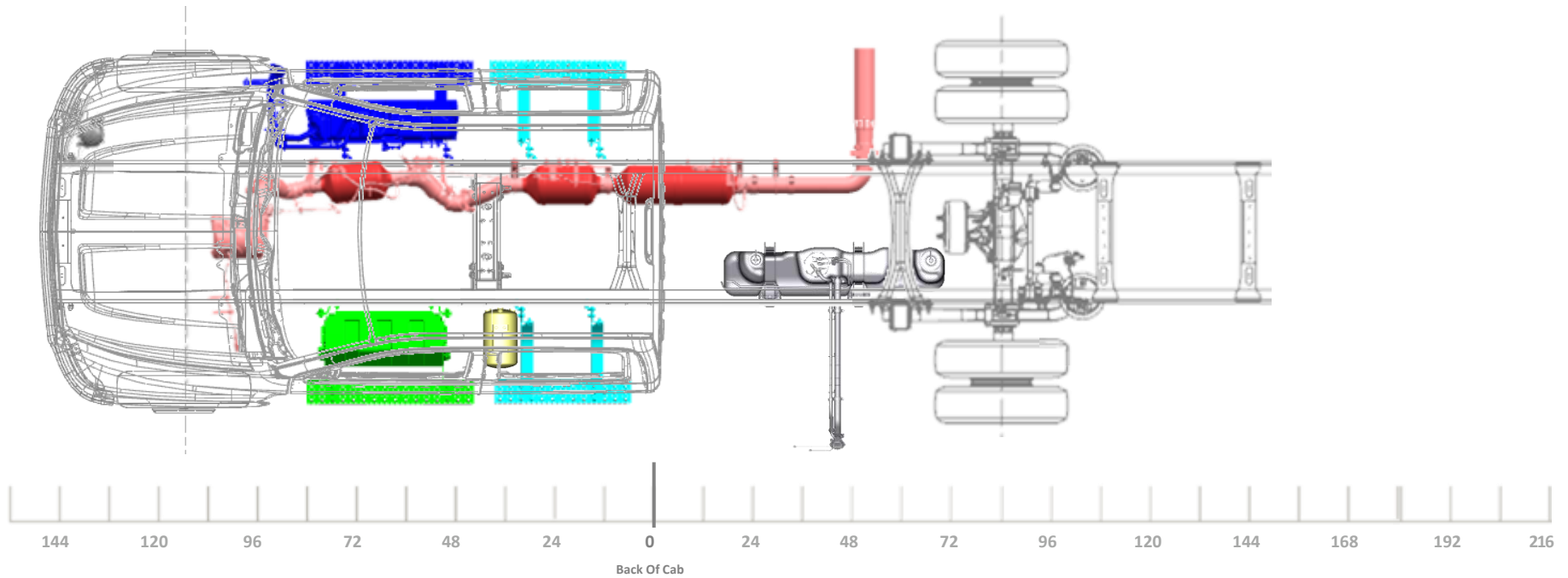

LAST REVISION: 9/28/2023

Model/Feature Information

Model:		C56043 K56043
Cab:		CREW CAB
Aftertreatment:		HORIZONTAL
Fuel Tank:	RPO NVK	25 GAL, CA MTD
Battery Box:	RPO 7Y9	TEMP MTD, 3 BATT
Air Tanks:		(1) OUTSIDE LEFT
DEF Tank:		6.75 GAL
Engine:		6.6L GM DURAMAX

General Configuration Information

4X2 OR 4X4 TRUCK CONFIGURATION
 VARI-RATE REAR SUSPENSION

SIDE EXIT TAILPIPE AHEAD OF REAR
 WHEELS, RT SIDE (RPO NPK)

OPTIONAL AIR DRYER FWD OUTSIDE
 RT (RPO KUT/JPY)

Minimum Wheelbase

199" WB (84" CA)
 49" OR 63" AF

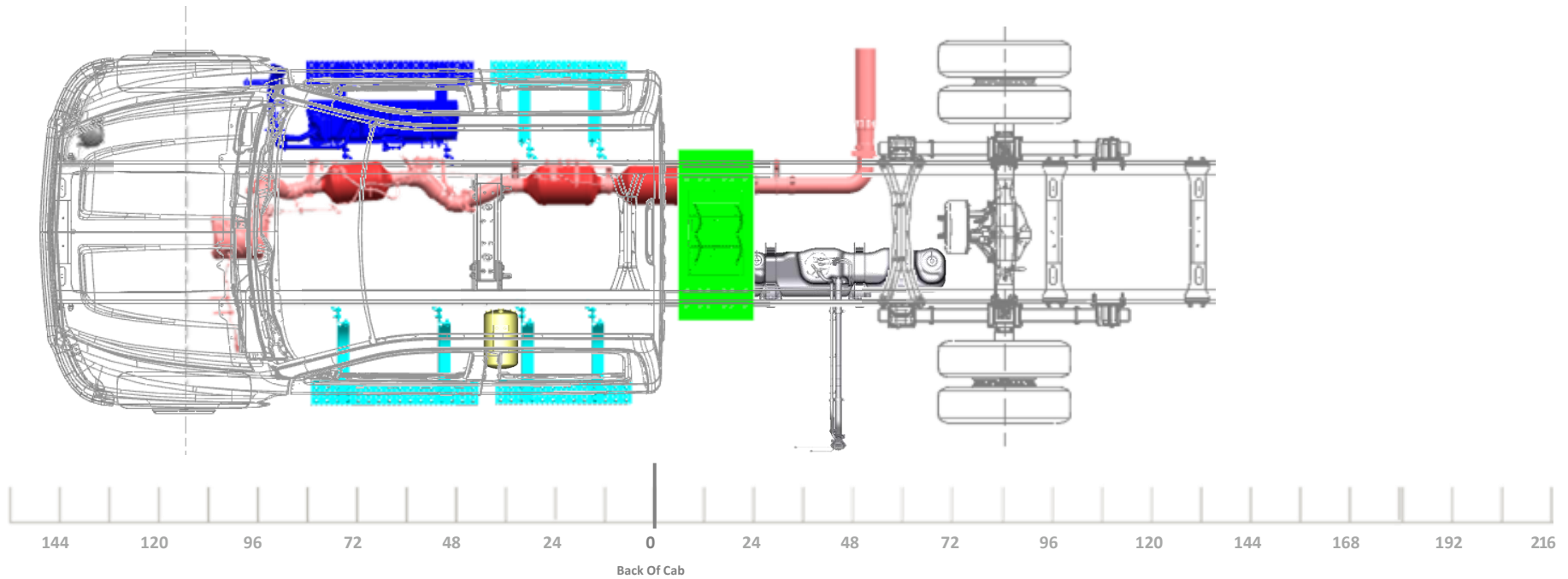

LAST REVISION: 9/28/2023

Model/Feature Information

Model:		C56043 K56043
Cab:		CREW CAB
Aftertreatment:		HORIZONTAL
Fuel Tank:	RPO NVK	25 GAL, CA MTD
Battery Box:	RPO 7Y9	TEMP MTD, 3 BATT
Air Tanks:		(1) OUTSIDE LEFT
DEF Tank:		6.75 GAL
Engine:		6.6L GM DURAMAX

General Configuration Information

4X2 TRUCK CONFIGURATION
REAR AIR SUSPENSION
SIDE EXIT TAILPIPE AHEAD OF REAR WHEELS, RT SIDE (RPO NPK)
OPTIONAL AIR DRYER FWD OUTSIDE RT (RPO KUT/JPY)

Minimum Wheelbase

199" WB (84" CA)
63" AF

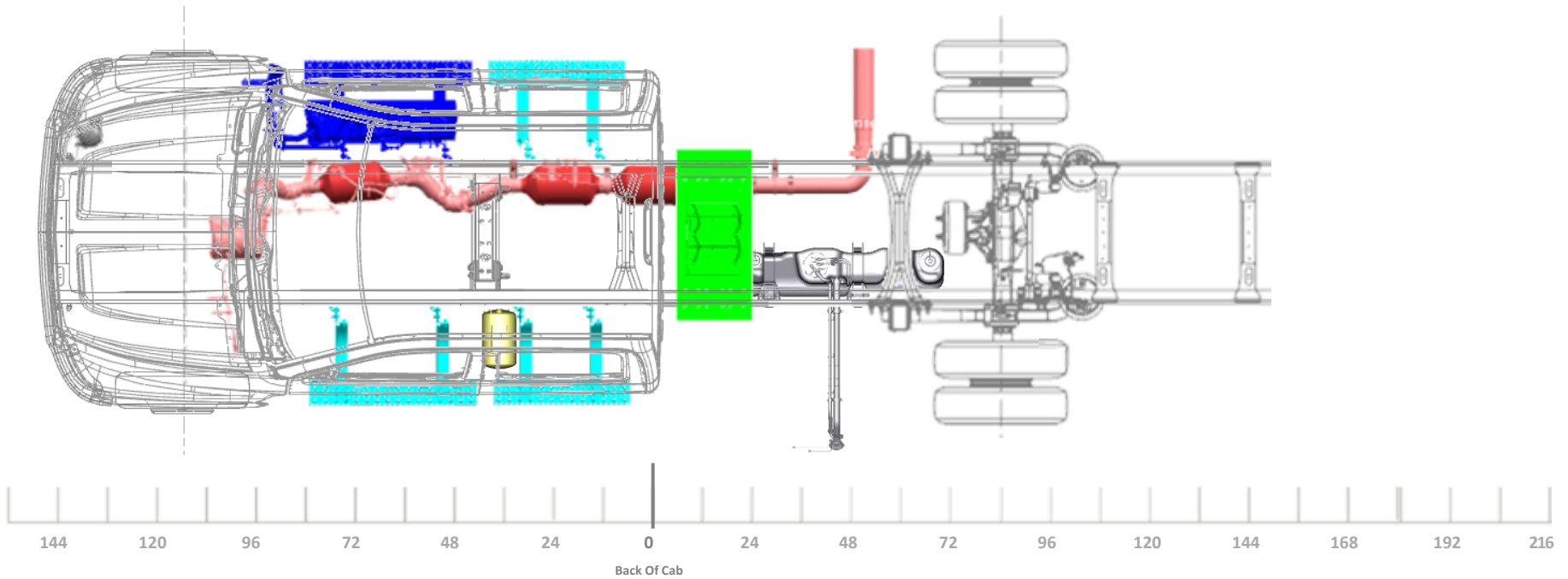

LAST REVISION: 9/28/2023

Model/Feature Information

Model:		C56043 K56043
Cab:		CREW CAB
Aftertreatment:		HORIZONTAL
Fuel Tank:	RPO NSQ	DUAL 25G CA, 40G AF
Battery Box:	RPO 7Y7/7Y8	28" STEEL, 2 BATTERIES
Air Tanks:		(1) OUTSIDE LEFT
DEF Tank:		6.75 GAL
Engine:		6.6L GM DURAMAX

General Configuration Information

4X2 OR 4X4 TRUCK CONFIGURATION
 VARI-RATE REAR SUSPENSION

STRAIGHT TAILPIPE (RPO N12)

OPTIONAL AIR DRYER FWD OUTSIDE
 RT (RPO KUT/JPY)

Minimum Wheelbase

199" WB (84" CA)
 49" OR 63" AF

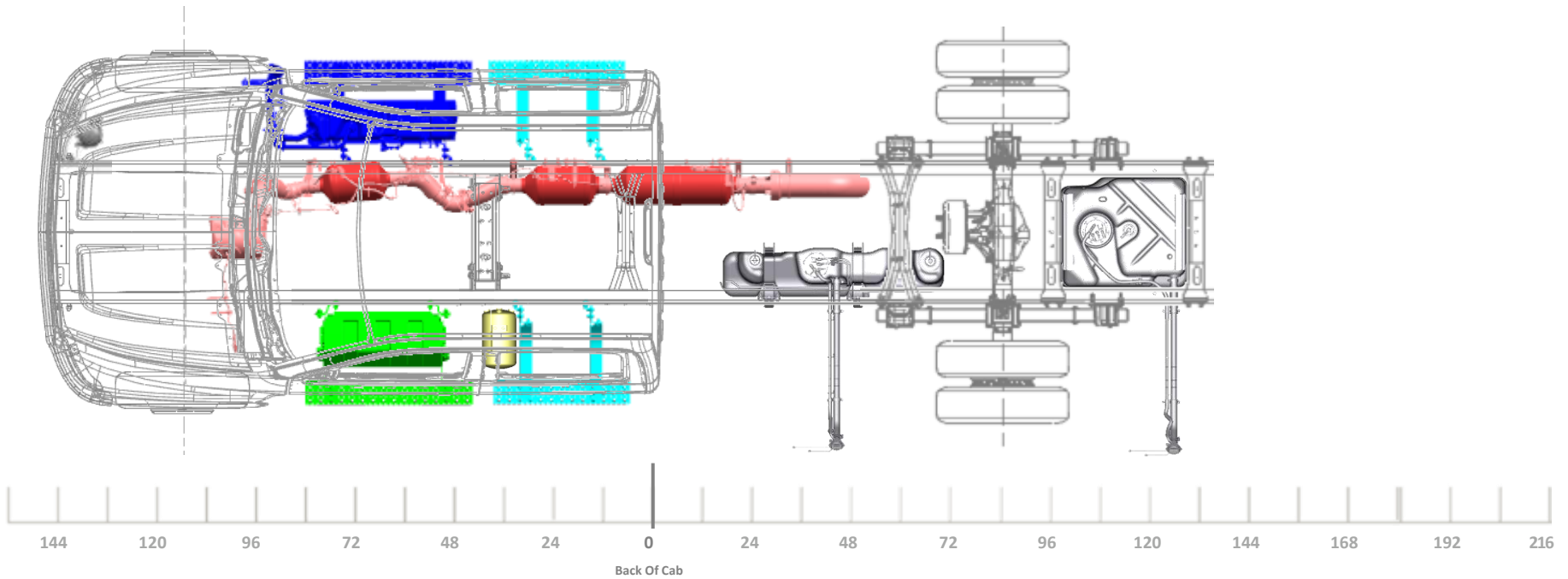

LAST REVISION: 9/28/2023

Model/Feature Information

Model:		C56043 K56043
Cab:		CREW CAB
Aftertreatment:		HORIZONTAL
Fuel Tank:	RPO NSQ	DUAL 25G CA, 40G AF
Battery Box:	RPO 7Y7/7Y8	28" STEEL, 2 BATTERIES
Air Tanks:		(1) OUTSIDE LEFT
DEF Tank:		6.75 GAL
Engine:		6.6L GM DURAMAX

General Configuration Information

4X2 TRUCK CONFIGURATION
REAR AIR SUSPENSION
STRAIGHT TAILPIPE (RPO N12)
OPTIONAL AIR DRYER FWD OUTSIDE RT (RPO KUT/JPY)

Minimum Wheelbase

199" WB (84" CA)
63" AF

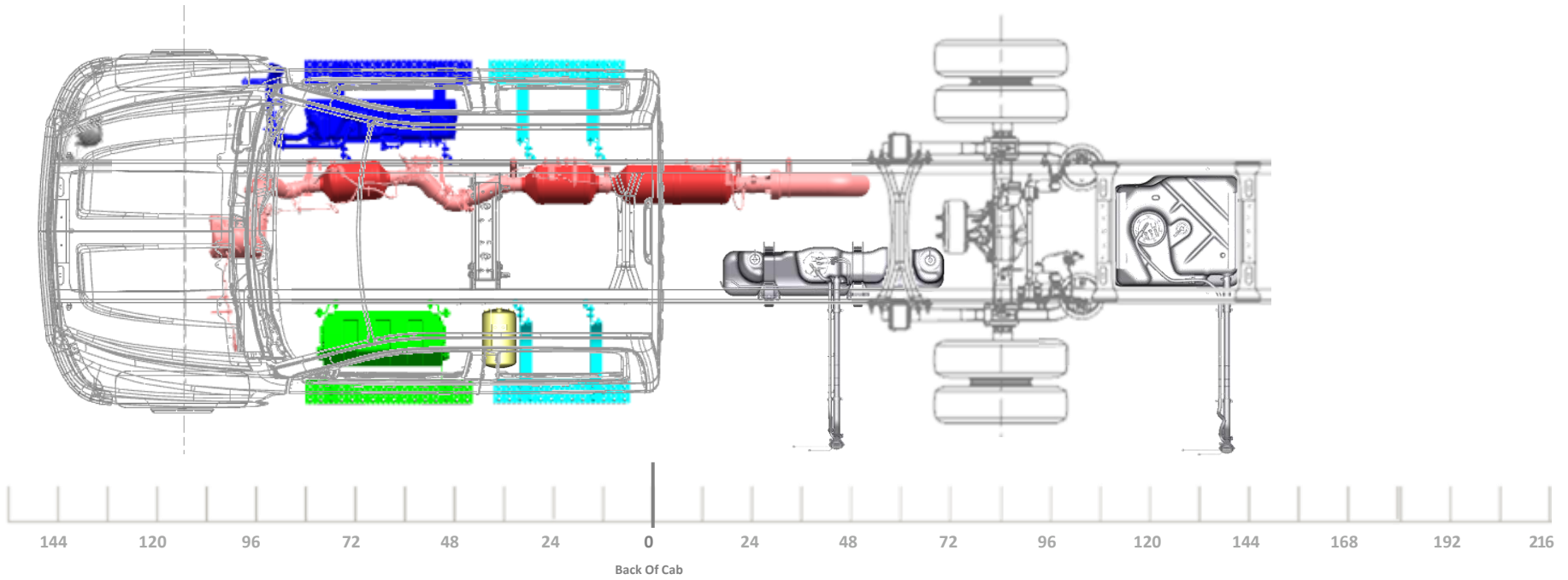

LAST REVISION: 9/28/2023

Model/Feature Information

Model:		C56043 K56043
Cab:		CREW CAB
Aftertreatment:		HORIZONTAL
Fuel Tank:	RPO NSQ	DUAL 25G CA, 40G AF
Battery Box:	RPO 7Y9	TEMP MTD, 3 BATT
Air Tanks:		(1) OUTSIDE LEFT
DEF Tank:		6.75 GAL
Engine:		6.6L GM DURAMAX

General Configuration Information

4X2 OR 4X4 TRUCK CONFIGURATION
VARI-RATE REAR SUSPENSION

STRAIGHT TAILPIPE (RPO N12)

OPTIONAL AIR DRYER FWD OUTSIDE
RT (RPO KUT/JPY)

Minimum Wheelbase

199" WB (84" CA)
49" OR 63" AF

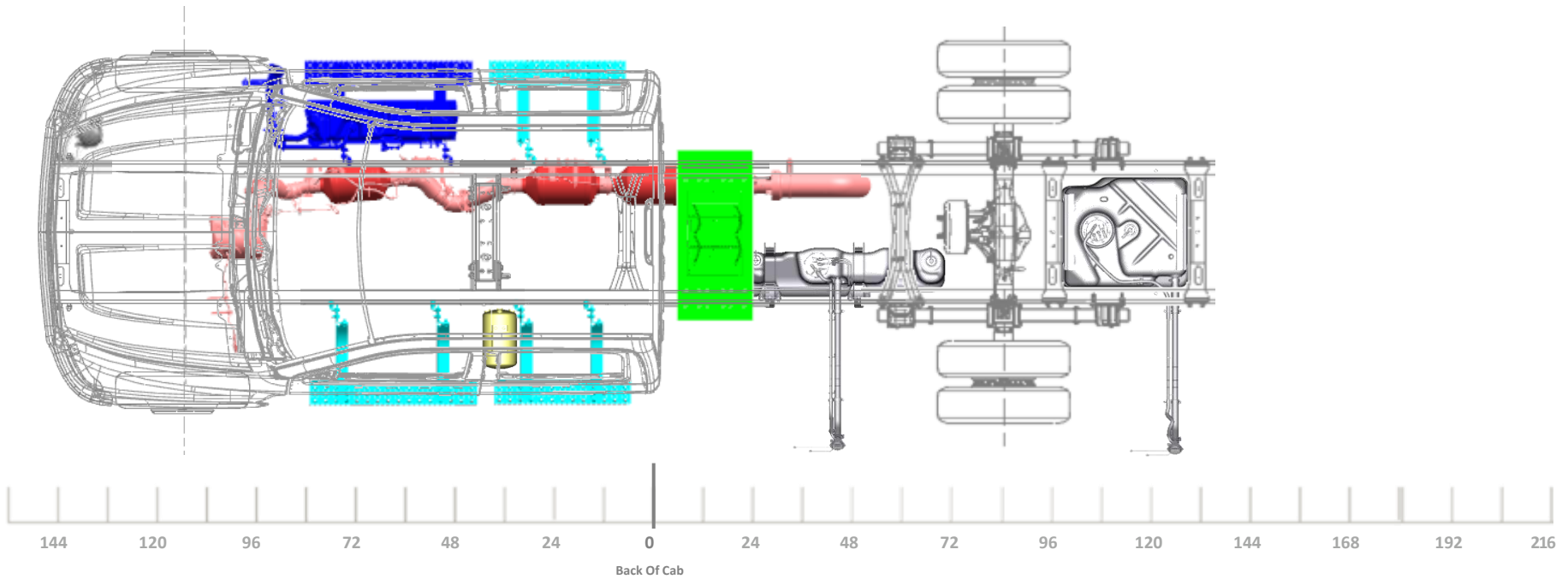

LAST REVISION: 9/28/2023

Model/Feature Information

Model:		C56043 K56043
Cab:		CREW CAB
Aftertreatment:		HORIZONTAL
Fuel Tank:	RPO NSQ	DUAL 25G CA, 40G AF
Battery Box:	RPO 7Y9	TEMP MTD, 3 BATT
Air Tanks:		(1) OUTSIDE LEFT
DEF Tank:		6.75 GAL
Engine:		6.6L GM DURAMAX

General Configuration Information

4X2 TRUCK CONFIGURATION
REAR AIR SUSPENSION
STRAIGHT TAILPIPE (RPO N12)
OPTIONAL AIR DRYER FWD OUTSIDE RT (RPO KUT/JPY)

Minimum Wheelbase

199" WB (84" CA)
63" AF

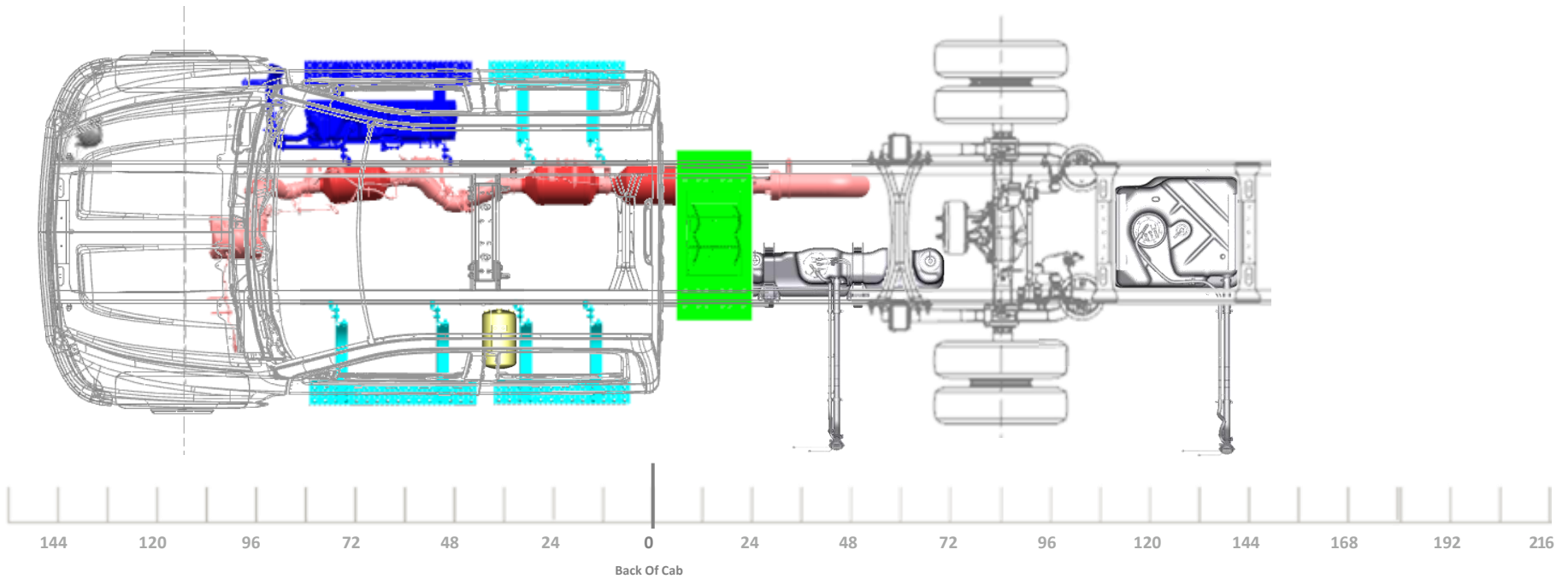

LAST REVISION: 9/28/2023

Model/Feature Information

Model:		C56043 K56043
Cab:		CREW CAB
Aftertreatment:		HORIZONTAL
Fuel Tank:	RPO NSQ	DUAL 25G CA, 40G AF
Battery Box:	RPO 7Y7/7Y8	28" STEEL, 2 BATTERIES
Air Tanks:		(1) OUTSIDE LEFT
DEF Tank:		6.75 GAL
Engine:		6.6L GM DURAMAX

General Configuration Information

4X2 OR 4X4 TRUCK CONFIGURATION
VARI-RATE REAR SUSPENSION
SIDE EXIT TAILPIPE AHEAD OF REAR WHEELS, RT SIDE (RPO NPK)
OPTIONAL AIR DRYER FWD OUTSIDE RT (RPO KUT/JPY)

Minimum Wheelbase

199" WB (84" CA)
49" OR 63" AF

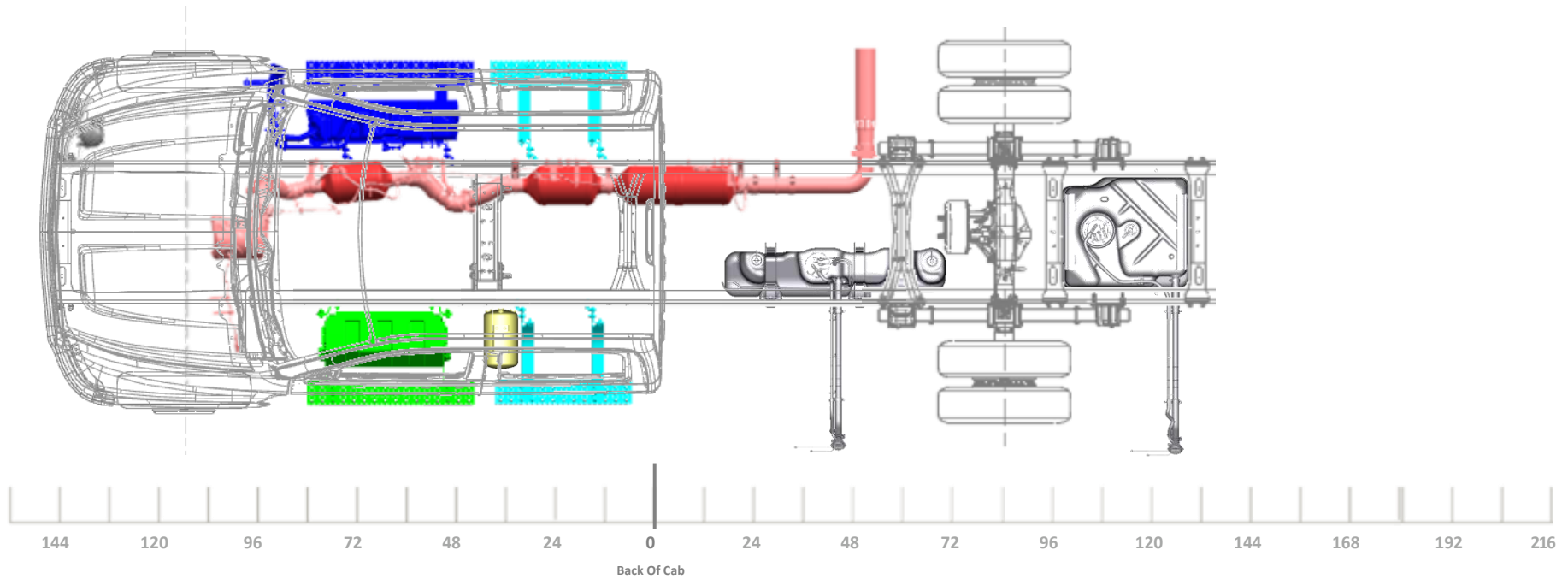

LAST REVISION: 9/28/2023

Model/Feature Information

Model:		C56043 K56043
Cab:		CREW CAB
Aftertreatment:		HORIZONTAL
Fuel Tank:	RPO NSQ	DUAL 25G CA, 40G AF
Battery Box:	RPO 7Y7/7Y8	28" STEEL, 2 BATTERIES
Air Tanks:		(1) OUTSIDE LEFT
DEF Tank:		6.75 GAL
Engine:		6.6L GM DURAMAX

General Configuration Information

4X2 TRUCK CONFIGURATION
REAR AIR SUSPENSION
SIDE EXIT TAILPIPE AHEAD OF REAR WHEELS, RT SIDE (RPO NPK)
OPTIONAL AIR DRYER FWD OUTSIDE RT (RPO KUT/JPY)

Minimum Wheelbase

199" WB (84" CA)
63" AF

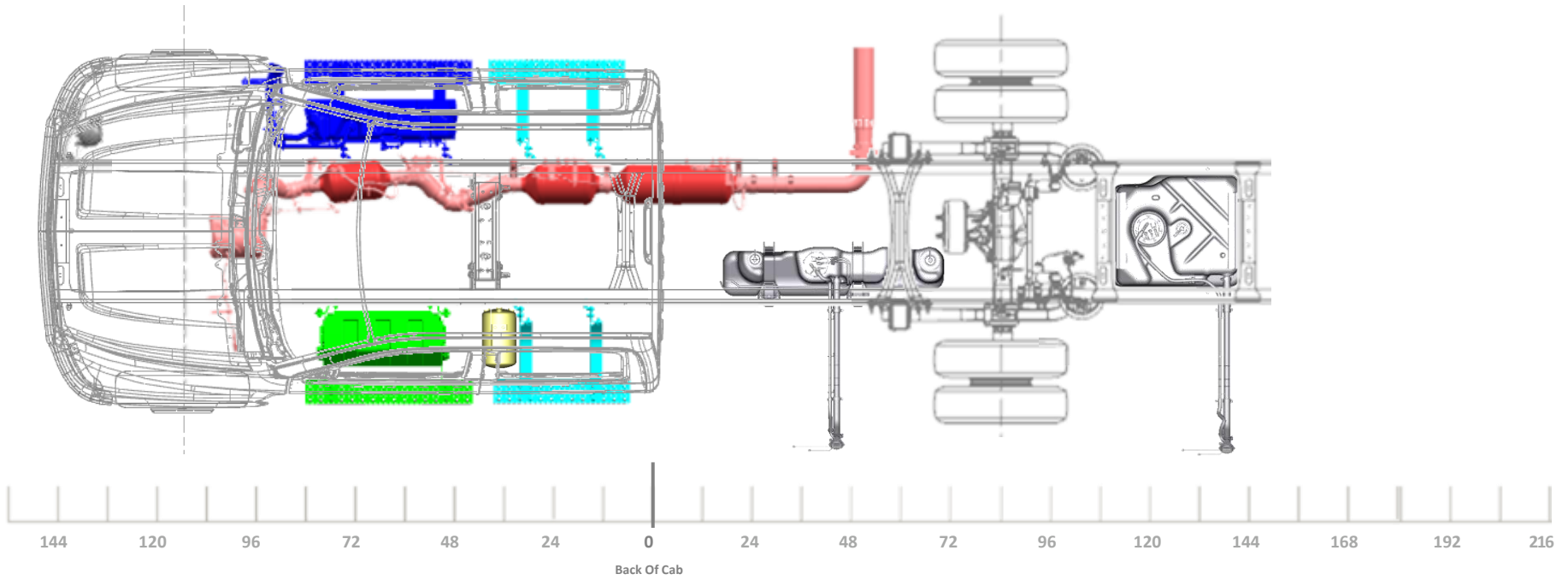

LAST REVISION: 9/28/2023

Model/Feature Information

Model:		C56043 K56043
Cab:		CREW CAB
Aftertreatment:		HORIZONTAL
Fuel Tank:	RPO NSQ	DUAL 25G CA, 40G AF
Battery Box:	RPO 7Y9	TEMP MTD, 3 BATT
Air Tanks:		(1) OUTSIDE LEFT
DEF Tank:		6.75 GAL
Engine:		6.6L GM DURAMAX

General Configuration Information

4X2 OR 4X4 TRUCK CONFIGURATION
 VARI-RATE REAR SUSPENSION

SIDE EXIT TAILPIPE AHEAD OF REAR
 WHEELS, RT SIDE (RPO NPK)

OPTIONAL AIR DRYER FWD OUTSIDE
 RT (RPO KUT/JPY)

Minimum Wheelbase

199" WB (84" CA)
 49" OR 63" AF

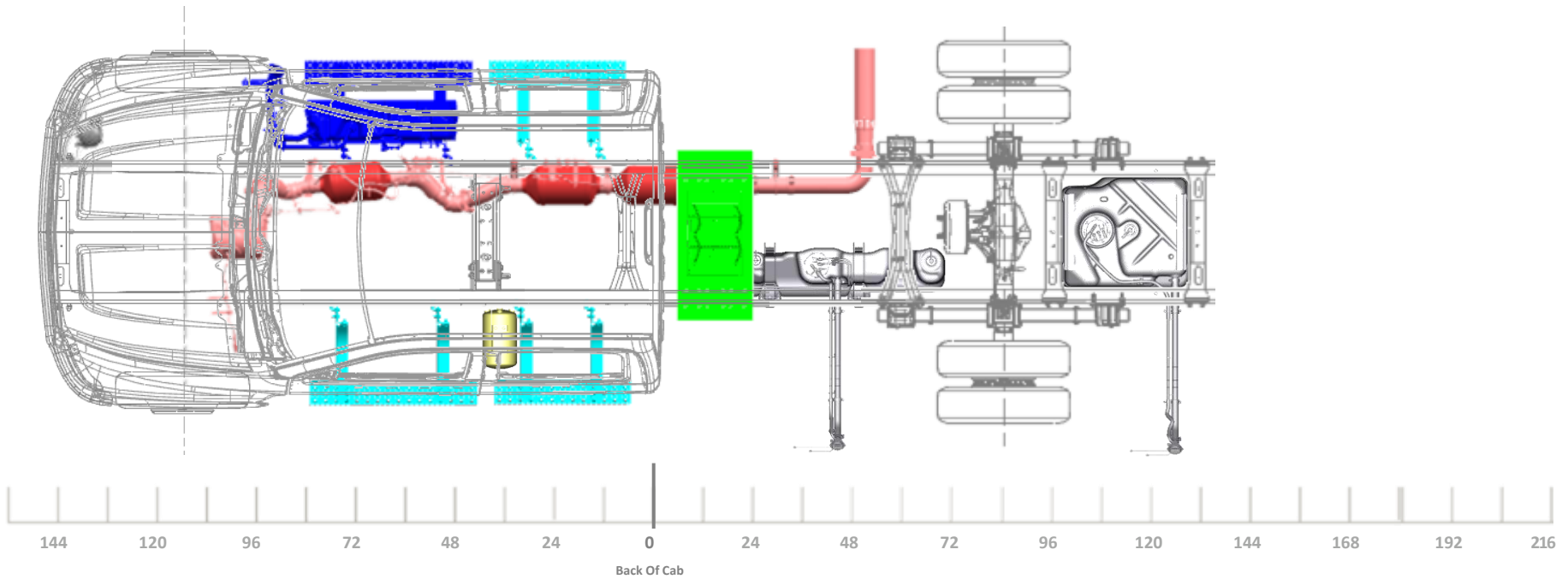

LAST REVISION: 9/28/2023

Model/Feature Information

Model:		C56043 K56043
Cab:		CREW CAB
Aftertreatment:		HORIZONTAL
Fuel Tank:	RPO NSQ	DUAL 25G CA, 40G AF
Battery Box:	RPO 7Y9	TEMP MTD, 3 BATT
Air Tanks:		(1) OUTSIDE LEFT
DEF Tank:		6.75 GAL
Engine:		6.6L GM DURAMAX

General Configuration Information

4X2 TRUCK CONFIGURATION
REAR AIR SUSPENSION
SIDE EXIT TAILPIPE AHEAD OF REAR WHEELS, RT SIDE (RPO NPK)
OPTIONAL AIR DRYER FWD OUTSIDE RT (RPO KUT/JPY)

Minimum Wheelbase

199" WB (84" CA)
63" AF

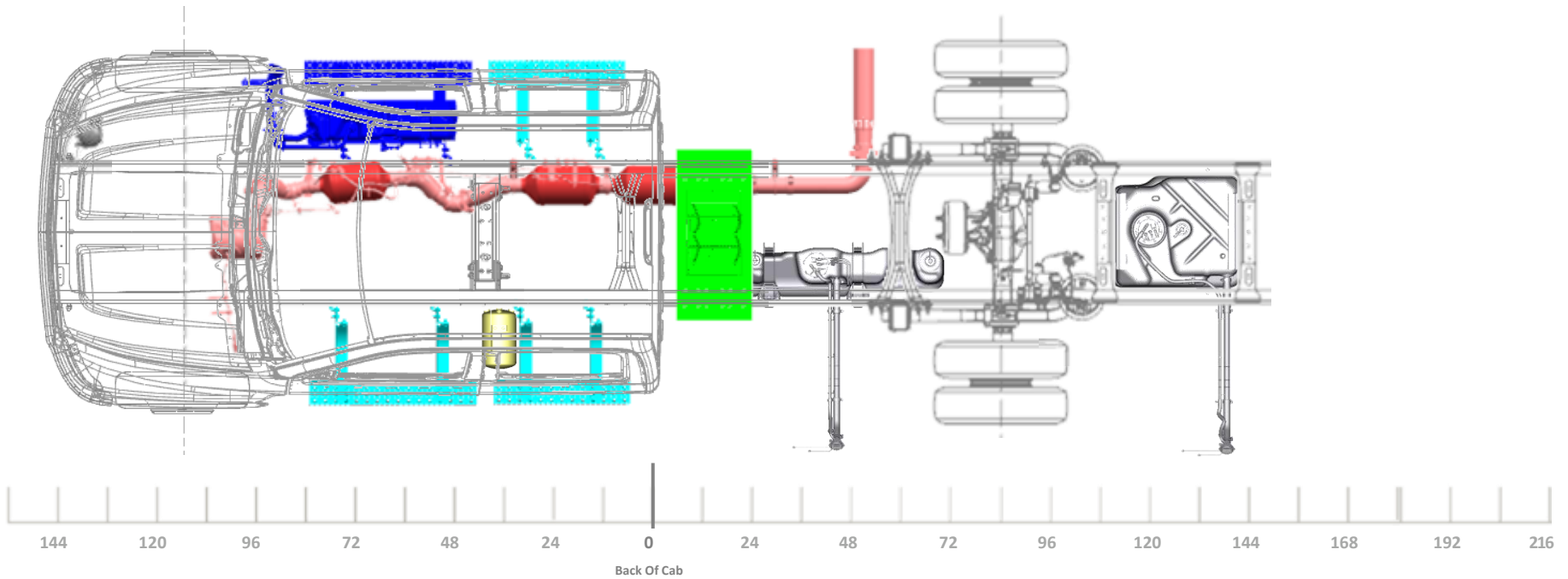

LAST REVISION: 9/28/2023

CREW CAB
219" WB

Model/Feature Information

Model:		C56043 K56043
Cab:		CREW CAB
Aftertreatment:		HORIZONTAL
Fuel Tank:	RPO N2L	40 GAL, AF MTD
Battery Box:	RPO 7Y7/7Y8	28" STEEL, 2 BATTERIES
Air Tanks:		(1) OUTSIDE LEFT
DEF Tank:		6.75 GAL
Engine:		6.6L GM DURAMAX

General Configuration Information

4X2 OR 4X4 TRUCK CONFIGURATION
 VARI-RATE REAR SUSPENSION

STRAIGHT TAILPIPE (RPO N12)

OPTIONAL AIR DRYER FWD OUTSIDE
 RT (RPO KUT/JPY)

Minimum Wheelbase

219" WB (104" CA)
 75" AF

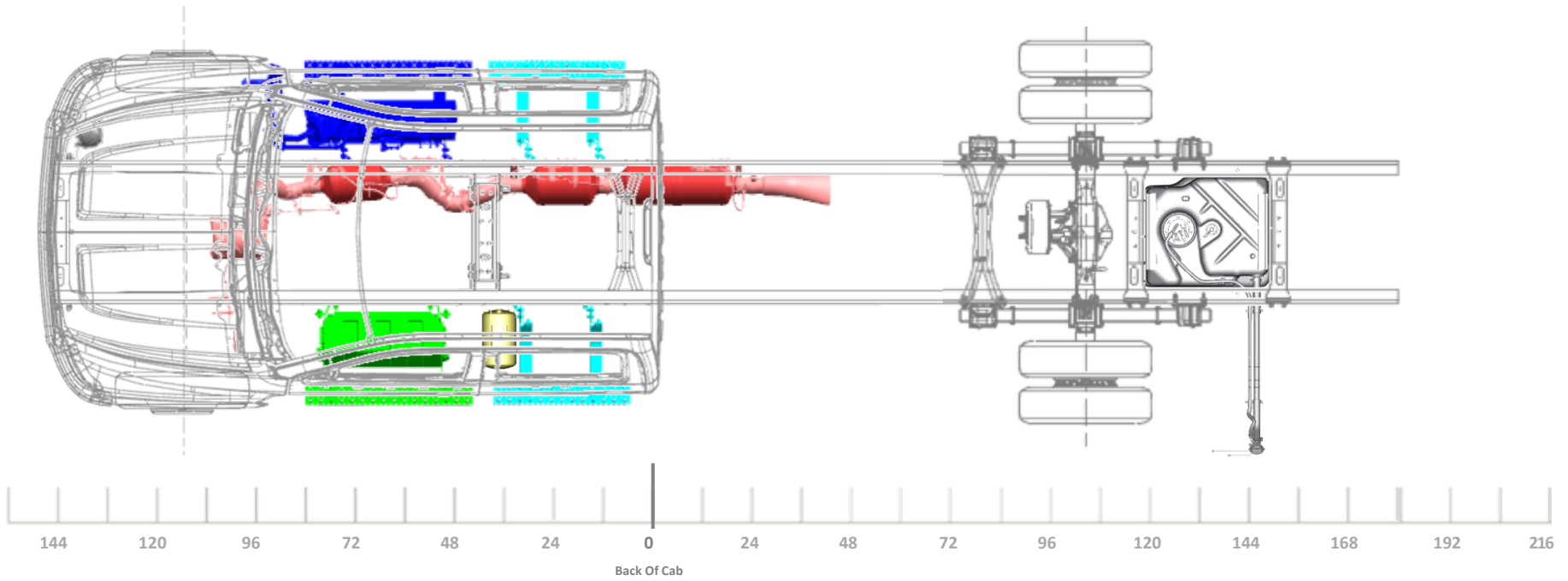

LAST REVISION: 9/28/2023

Model/Feature Information

Model:		C56043 K56043
Cab:		CREW CAB
Aftertreatment:		HORIZONTAL
Fuel Tank:	RPO N2L	40 GAL, AF MTD
Battery Box:	RPO 7Y7/7Y8	28" STEEL, 2 BATTERIES
Air Tanks:		(1) OUTSIDE LEFT
DEF Tank:		6.75 GAL
Engine:		6.6L GM DURAMAX

General Configuration Information

4X2 TRUCK CONFIGURATION
REAR AIR SUSPENSION
STRAIGHT TAILPIPE (RPO N12)
OPTIONAL AIR DRYER FWD OUTSIDE RT (RPO KUT/JPY)

Minimum Wheelbase

219" WB (104" CA)
75" AF

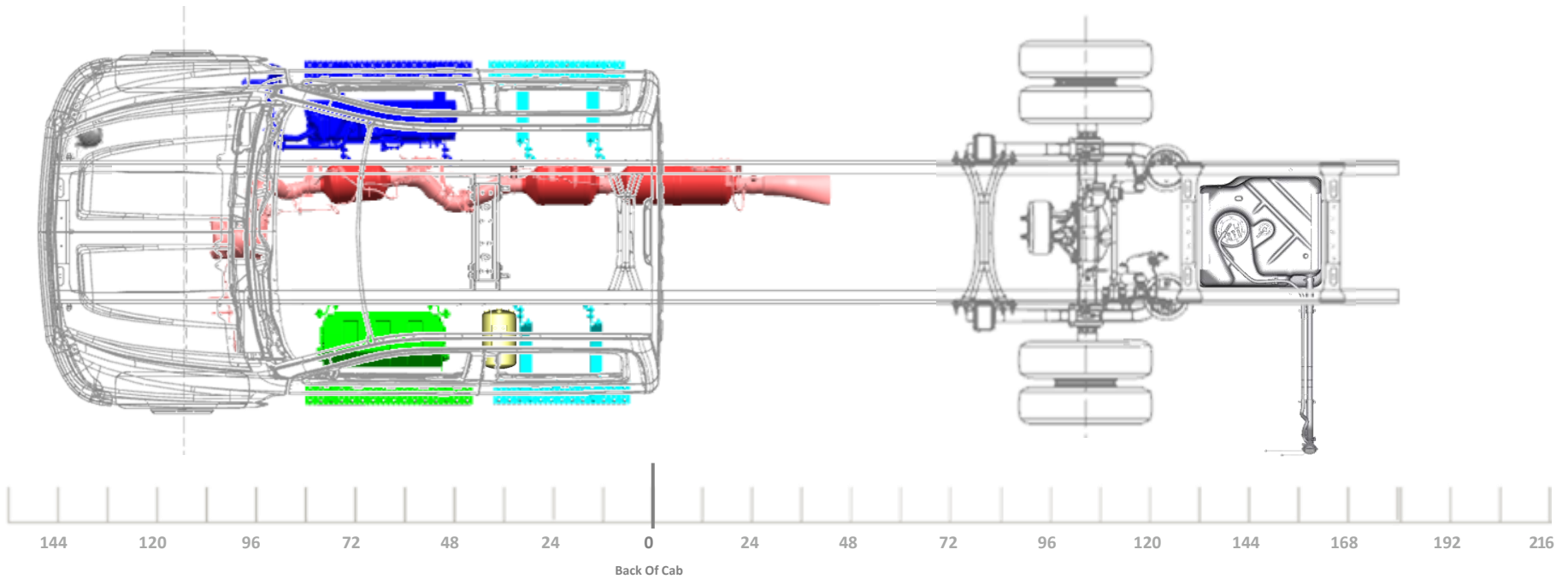

LAST REVISION: 9/28/2023

Model/Feature Information

Model:		C56043 K56043
Cab:		CREW CAB
Aftertreatment:		HORIZONTAL
Fuel Tank:	RPO N2L	40 GAL, AF MTD
Battery Box:	RPO 7Y9	TEMP MTD, 3 BATT
Air Tanks:		(1) OUTSIDE LEFT
DEF Tank:		6.75 GAL
Engine:		6.6L GM DURAMAX

General Configuration Information

4X2 OR 4X4 TRUCK CONFIGURATION
 VARI-RATE REAR SUSPENSION

STRAIGHT TAILPIPE (RPO N12)

OPTIONAL AIR DRYER FWD OUTSIDE
 RT (RPO KUT/JPY)

Minimum Wheelbase

219" WB (104" CA)
 75" AF

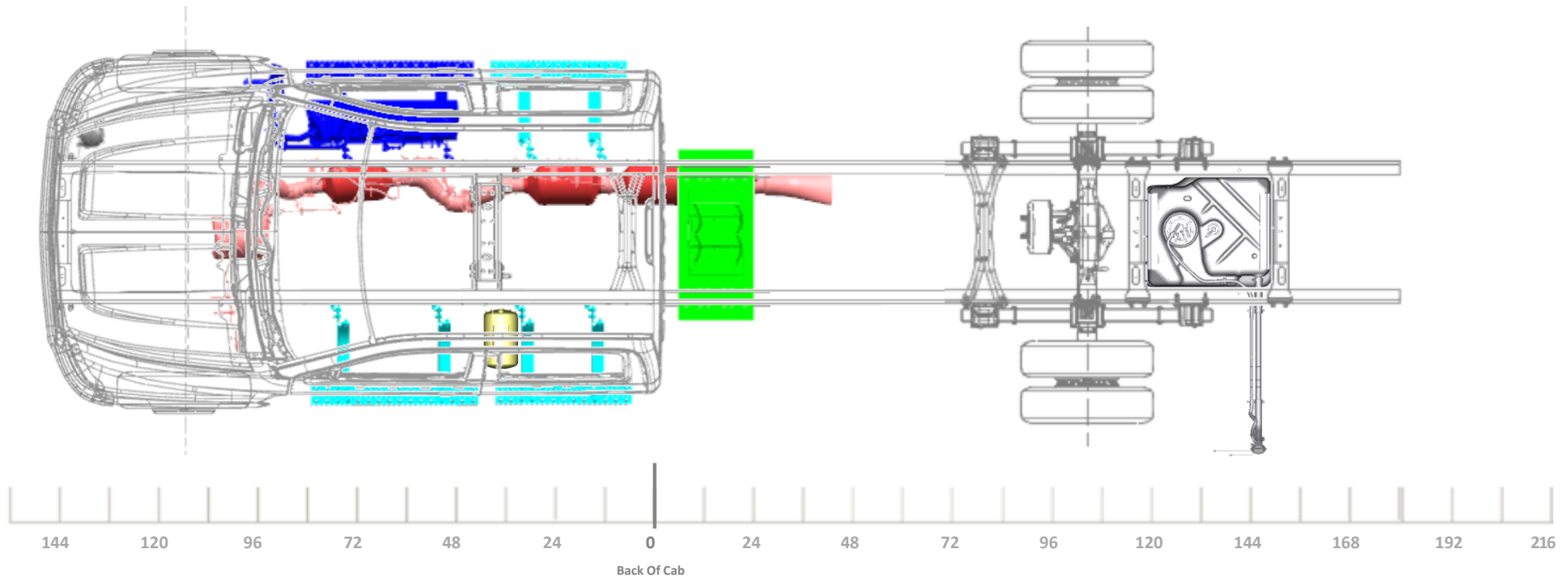

LAST REVISION: 9/28/2023

Model/Feature Information

Model:		C56043 K56043
Cab:		CREW CAB
Aftertreatment:		HORIZONTAL
Fuel Tank:	RPO N2L	40 GAL, AF MTD
Battery Box:	RPO 7Y9	TEMP MTD, 3 BATT
Air Tanks:		(1) OUTSIDE LEFT
DEF Tank:		6.75 GAL
Engine:		6.6L GM DURAMAX

General Configuration Information

4X2 TRUCK CONFIGURATION
REAR AIR SUSPENSION
STRAIGHT TAILPIPE (RPO N12)
OPTIONAL AIR DRYER FWD OUTSIDE RT (RPO KUT/JPY)

Minimum Wheelbase

219" WB (104" CA)
75" AF

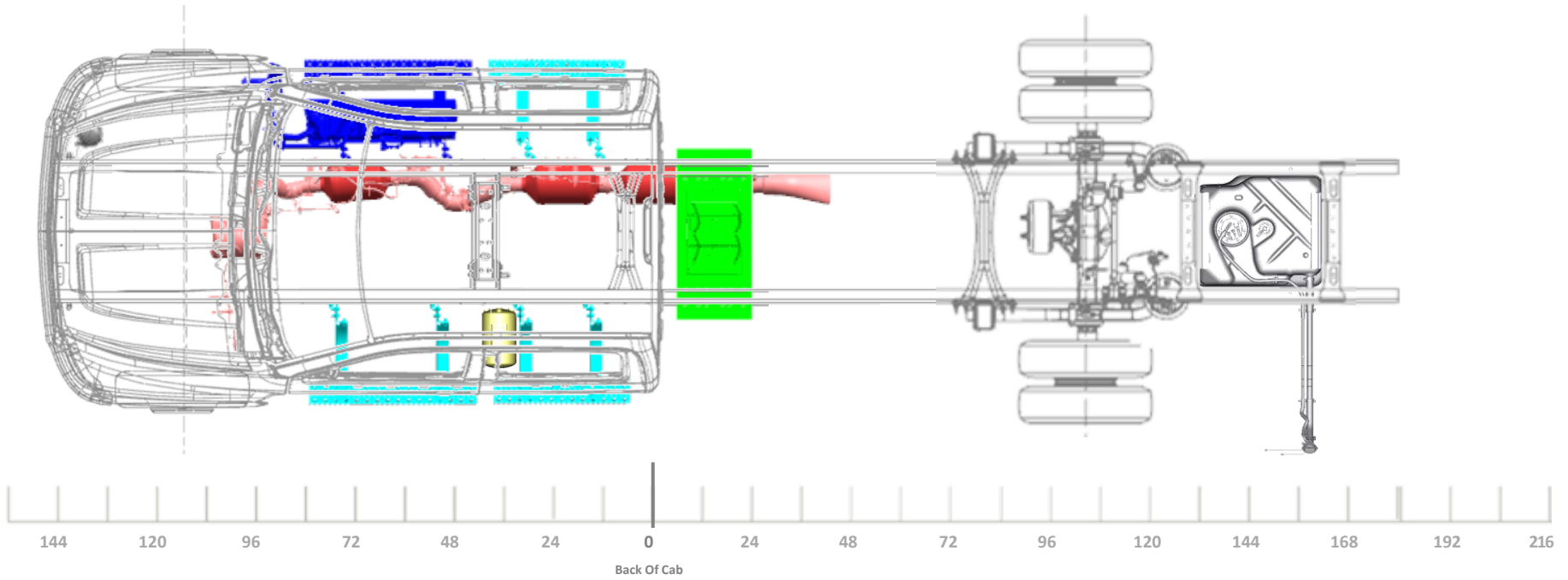

LAST REVISION: 9/28/2023

Model/Feature Information

Model:		C56043 K56043
Cab:		CREW CAB
Aftertreatment:		HORIZONTAL
Fuel Tank:	RPO N2L	40 GAL, AF MTD
Battery Box:	RPO 7Y7/7Y8	28" STEEL, 2 BATTERIES
Air Tanks:		(1) OUTSIDE LEFT
DEF Tank:		6.75 GAL
Engine:		6.6L GM DURAMAX

General Configuration Information

4X2 OR 4X4 TRUCK CONFIGURATION
 VARI-RATE REAR SUSPENSION
 SIDE EXIT TAILPIPE AHEAD OF REAR WHEELS, LT SIDE (RPO NPJ)
 OPTIONAL AIR DRYER FWD OUTSIDE RT (RPO KUT/JPY)

Minimum Wheelbase

219" WB (104" CA)
 75" AF

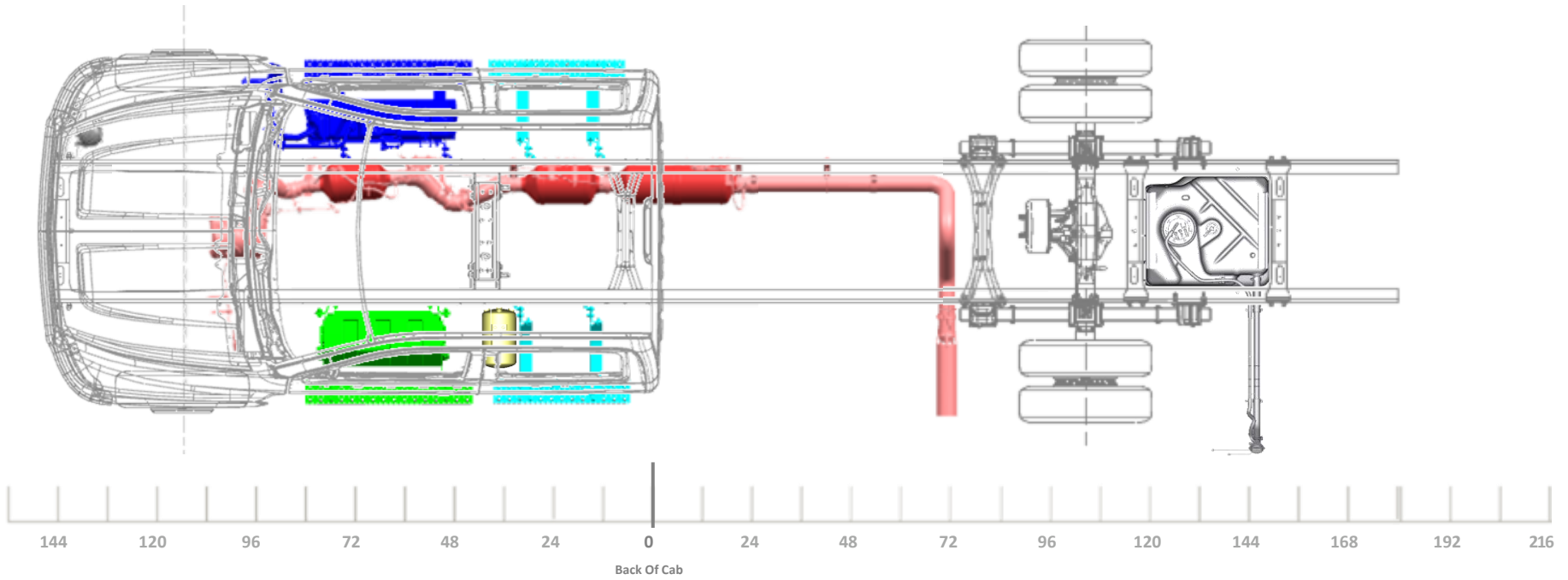

LAST REVISION: 9/28/2023

Model/Feature Information

Model:		C56043 K56043
Cab:		CREW CAB
Aftertreatment:		HORIZONTAL
Fuel Tank:	RPO N2L	40 GAL, AF MTD
Battery Box:	RPO 7Y7/7Y8	28" STEEL, 2 BATTERIES
Air Tanks:		(1) OUTSIDE LEFT
DEF Tank:		6.75 GAL
Engine:		6.6L GM DURAMAX

General Configuration Information

4X2 TRUCK CONFIGURATION
REAR AIR SUSPENSION
SIDE EXIT TAILPIPE AHEAD OF REAR WHEELS, LT SIDE (RPO NPJ)
OPTIONAL AIR DRYER FWD OUTSIDE RT (RPO KUT/JPY)

Minimum Wheelbase

219" WB (104" CA)
75" AF

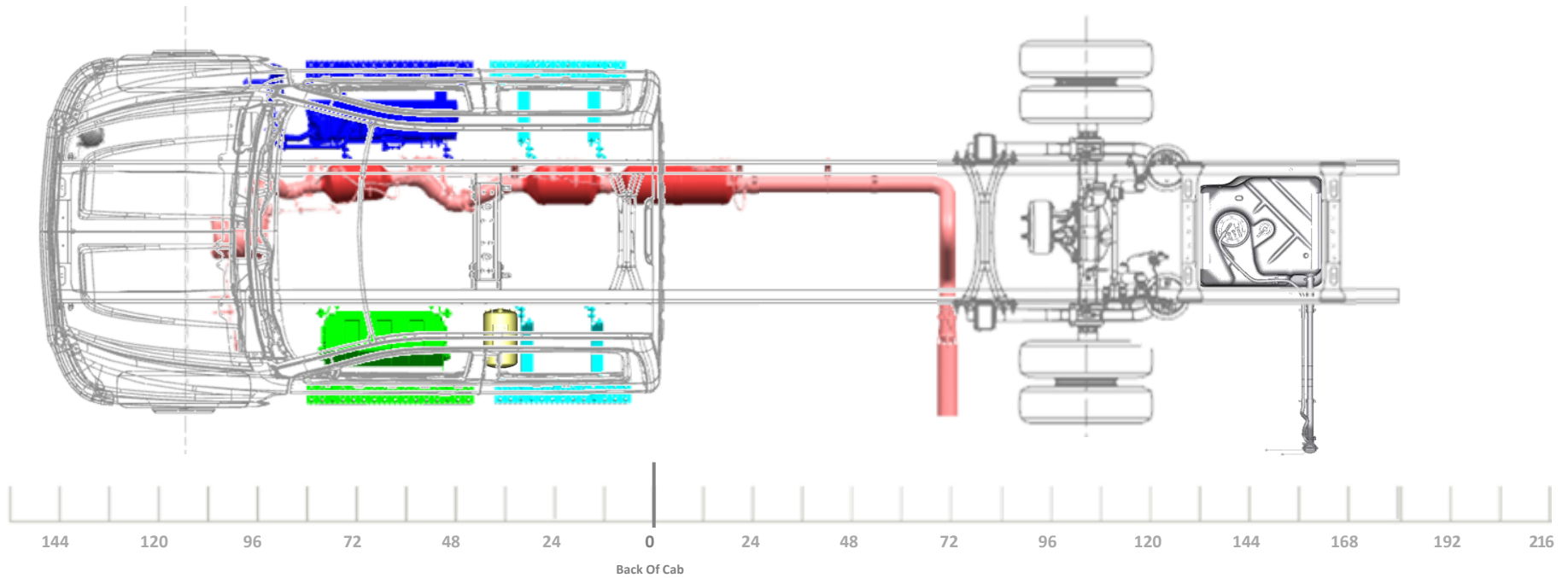

LAST REVISION: 9/28/2023

Model/Feature Information

Model:		C56043 K56043
Cab:		CREW CAB
Aftertreatment:		HORIZONTAL
Fuel Tank:	RPO N2L	40 GAL, AF MTD
Battery Box:	RPO 7Y9	TEMP MTD, 3 BATT
Air Tanks:		(1) OUTSIDE LEFT
DEF Tank:		6.75 GAL
Engine:		6.6L GM DURAMAX

General Configuration Information

4X2 OR 4X4 TRUCK CONFIGURATION
 VARI-RATE REAR SUSPENSION

SIDE EXIT TAILPIPE AHEAD OF REAR
 WHEELS, LT SIDE (RPO NPJ)

OPTIONAL AIR DRYER FWD OUTSIDE
 RT (RPO KUT/JPY)

Minimum Wheelbase

219" WB (104" CA)
 75" AF

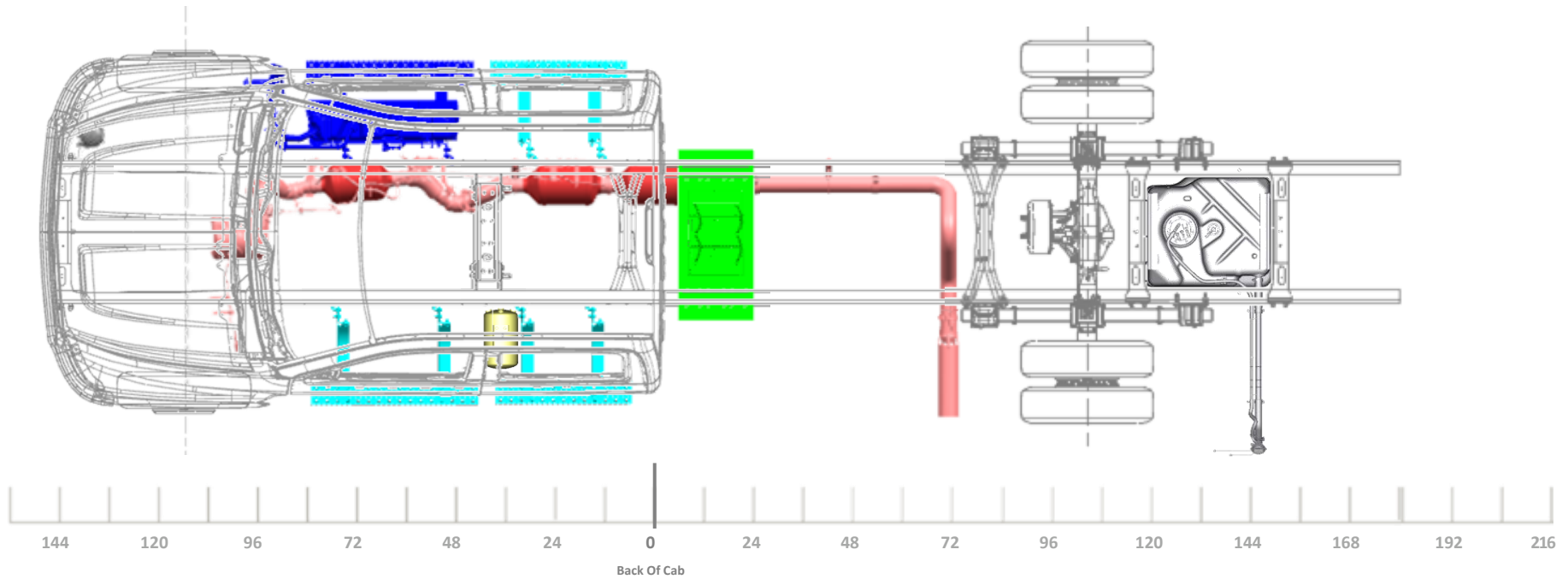

LAST REVISION: 9/28/2023

Model/Feature Information

Model:		C56043 K56043
Cab:		CREW CAB
Aftertreatment:		HORIZONTAL
Fuel Tank:	RPO N2L	40 GAL, AF MTD
Battery Box:	RPO 7Y9	TEMP MTD, 3 BATT
Air Tanks:		(1) OUTSIDE LEFT
DEF Tank:		6.75 GAL
Engine:		6.6L GM DURAMAX

General Configuration Information

4X2 TRUCK CONFIGURATION
 REAR AIR SUSPENSION
 SIDE EXIT TAILPIPE AHEAD OF REAR WHEELS, LT SIDE (RPO NPJ)
 OPTIONAL AIR DRYER FWD OUTSIDE RT (RPO KUT/JPY)

Minimum Wheelbase

219" WB (104" CA)
 75" AF

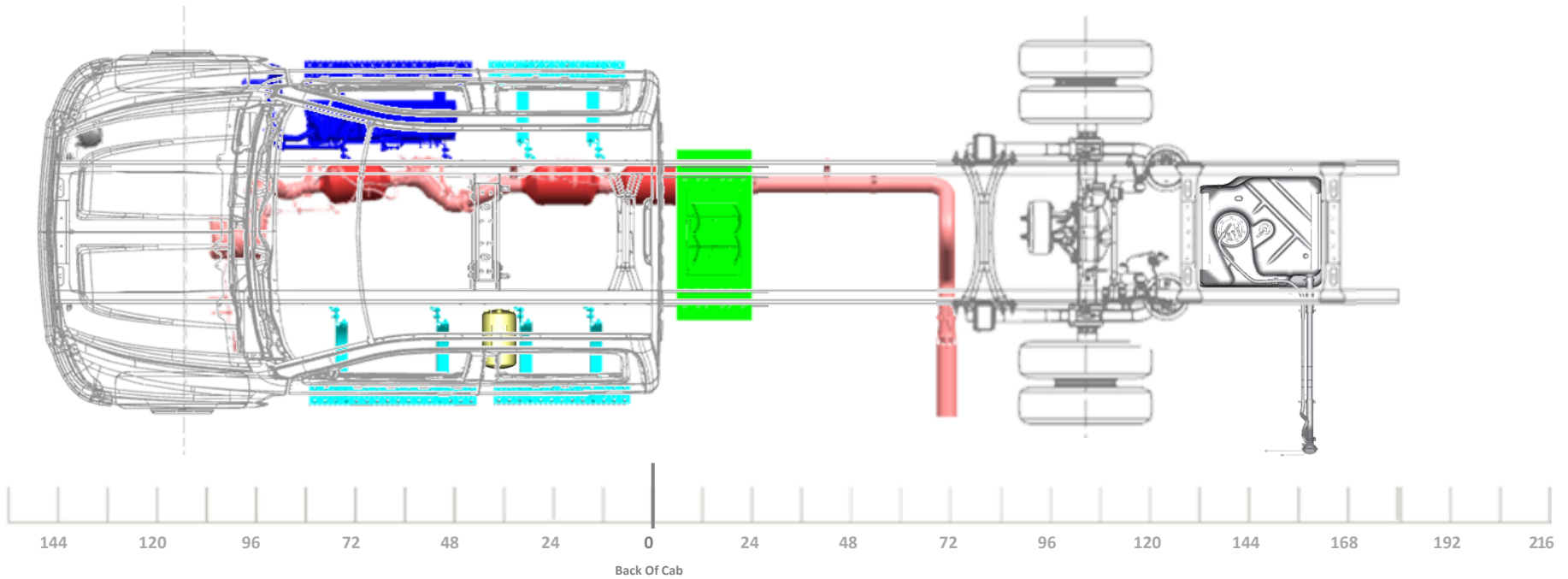

LAST REVISION: 9/28/2023

Model/Feature Information

Model:		C56043 K56043
Cab:		CREW CAB
Aftertreatment:		HORIZONTAL
Fuel Tank:	RPO N2L	40 GAL, AF MTD
Battery Box:	RPO 7Y7/7Y8	28" STEEL, 2 BATTERIES
Air Tanks:		(1) OUTSIDE LEFT
DEF Tank:		6.75 GAL
Engine:		6.6L GM DURAMAX

General Configuration Information

4X2 OR 4X4 TRUCK CONFIGURATION
 VARI-RATE REAR SUSPENSION
 SIDE EXIT TAILPIPE AHEAD OF REAR WHEELS, RT SIDE (RPO NPK)
 OPTIONAL AIR DRYER FWD OUTSIDE RT (RPO KUT/JPY)

Minimum Wheelbase

219" WB (104" CA)
 75" AF

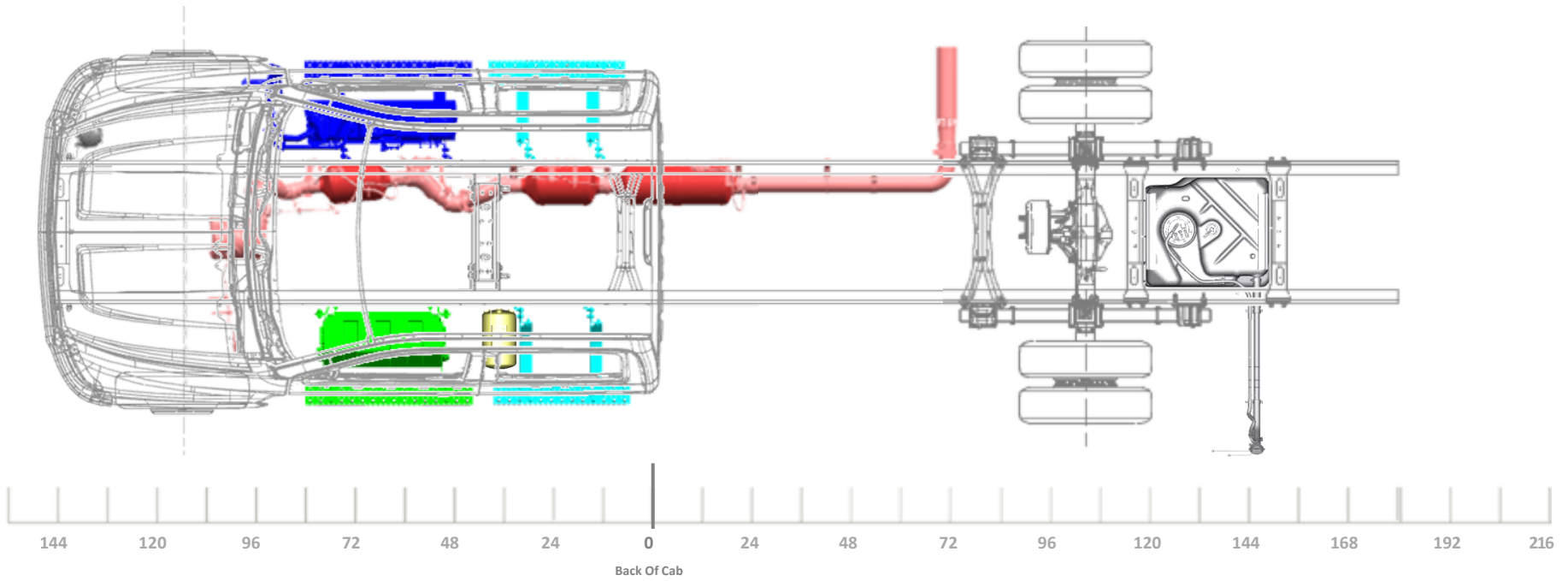

LAST REVISION: 9/28/2023

Model/Feature Information

Model:		C56043 K56043
Cab:		CREW CAB
Aftertreatment:		HORIZONTAL
Fuel Tank:	RPO N2L	40 GAL, AF MTD
Battery Box:	RPO 7Y7/7Y8	28" STEEL, 2 BATTERIES
Air Tanks:		(1) OUTSIDE LEFT
DEF Tank:		6.75 GAL
Engine:		6.6L GM DURAMAX

General Configuration Information

4X2 TRUCK CONFIGURATION
REAR AIR SUSPENSION
SIDE EXIT TAILPIPE AHEAD OF REAR WHEELS, RT SIDE (RPO NPK)
OPTIONAL AIR DRYER FWD OUTSIDE RT (RPO KUT/JPY)

Minimum Wheelbase

219" WB (104" CA)
75" AF

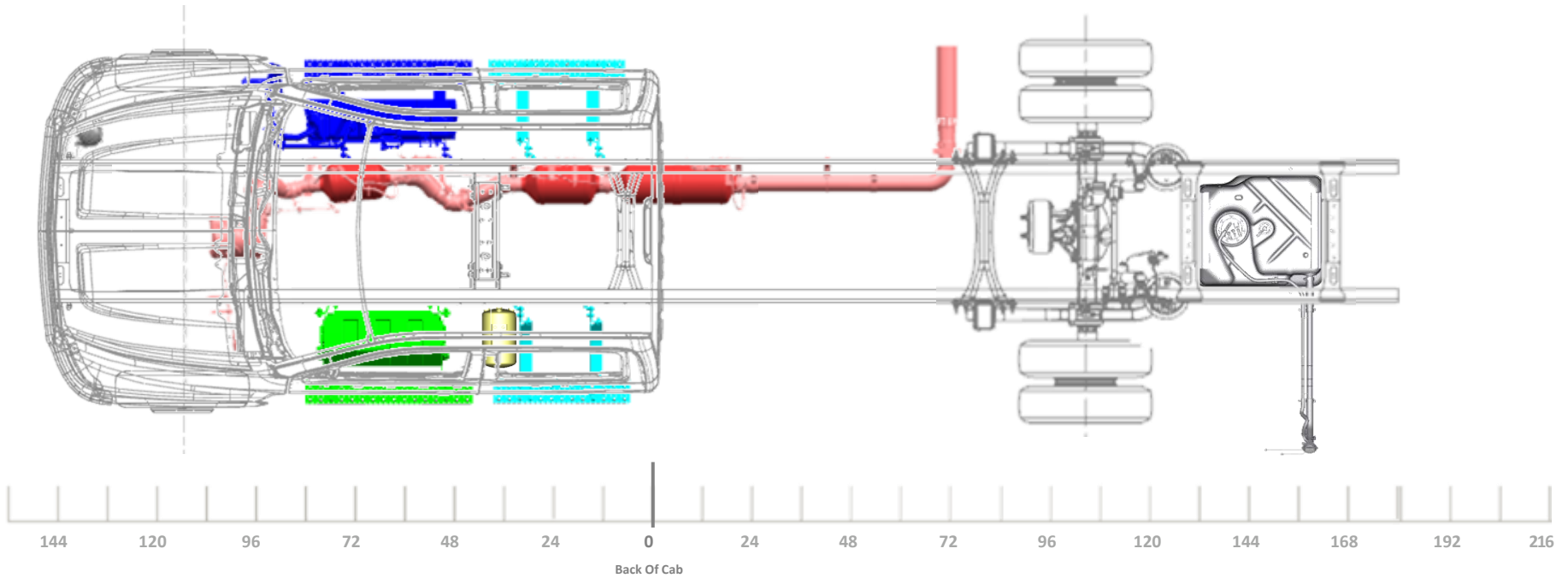

LAST REVISION: 9/28/2023

Model/Feature Information

Model:		C56043 K56043
Cab:		CREW CAB
Aftertreatment:		HORIZONTAL
Fuel Tank:	RPO N2L	40 GAL, AF MTD
Battery Box:	RPO 7Y9	TEMP MTD, 3 BATT
Air Tanks:		(1) OUTSIDE LEFT
DEF Tank:		6.75 GAL
Engine:		6.6L GM DURAMAX

General Configuration Information

4X2 OR 4X4 TRUCK CONFIGURATION
 VARI-RATE REAR SUSPENSION
 SIDE EXIT TAILPIPE AHEAD OF REAR WHEELS, RT SIDE (RPO NPK)
 OPTIONAL AIR DRYER FWD OUTSIDE RT (RPO KUT/JPY)

Minimum Wheelbase

219" WB (104" CA)
 75" AF

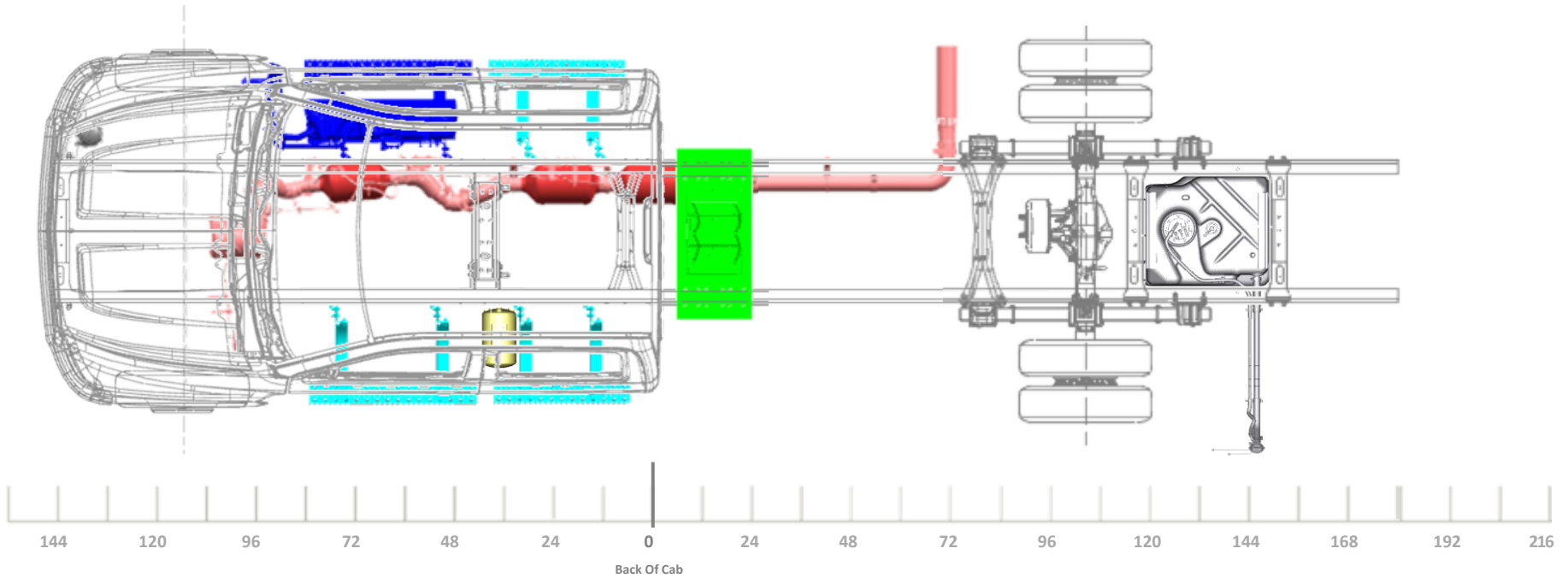

LAST REVISION: 9/28/2023

Model/Feature Information

Model:		C56043 K56043
Cab:		CREW CAB
Aftertreatment:		HORIZONTAL
Fuel Tank:	RPO N2L	40 GAL, AF MTD
Battery Box:	RPO 7Y9	TEMP MTD, 3 BATT
Air Tanks:		(1) OUTSIDE LEFT
DEF Tank:		6.75 GAL
Engine:		6.6L GM DURAMAX

General Configuration Information

4X2 TRUCK CONFIGURATION
 REAR AIR SUSPENSION
 SIDE EXIT TAILPIPE AHEAD OF REAR WHEELS, RT SIDE (RPO NPK)
 OPTIONAL AIR DRYER FWD OUTSIDE RT (RPO KUT/JPY)

Minimum Wheelbase

219" WB (104" CA)
 75" AF

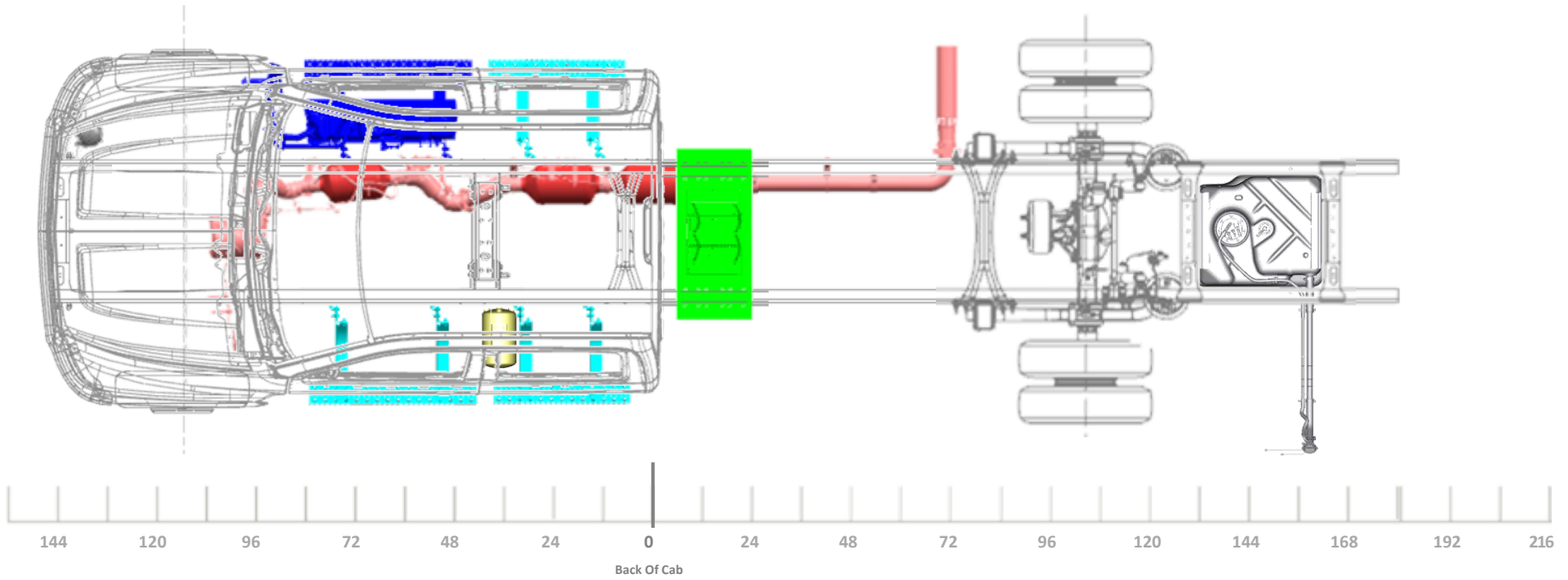

LAST REVISION: 9/28/2023

Model/Feature Information

Model:		C56043 K56043
Cab:		CREW CAB
Aftertreatment:		HORIZONTAL
Fuel Tank:	RPO NVK	25 GAL, CA MTD
Battery Box:	RPO 7Y7/7Y8	28" STEEL, 2 BATTERIES
Air Tanks:		(1) OUTSIDE LEFT
DEF Tank:		6.75 GAL
Engine:		6.6L GM DURAMAX

General Configuration Information

4X2 OR 4X4 TRUCK CONFIGURATION
VARI-RATE REAR SUSPENSION
STRAIGHT TAILPIPE (RPO N12)
OPTIONAL AIR DRYER FWD OUTSIDE RT (RPO KUT/JPY)

Minimum Wheelbase

219" WB (104" CA)
75" AF

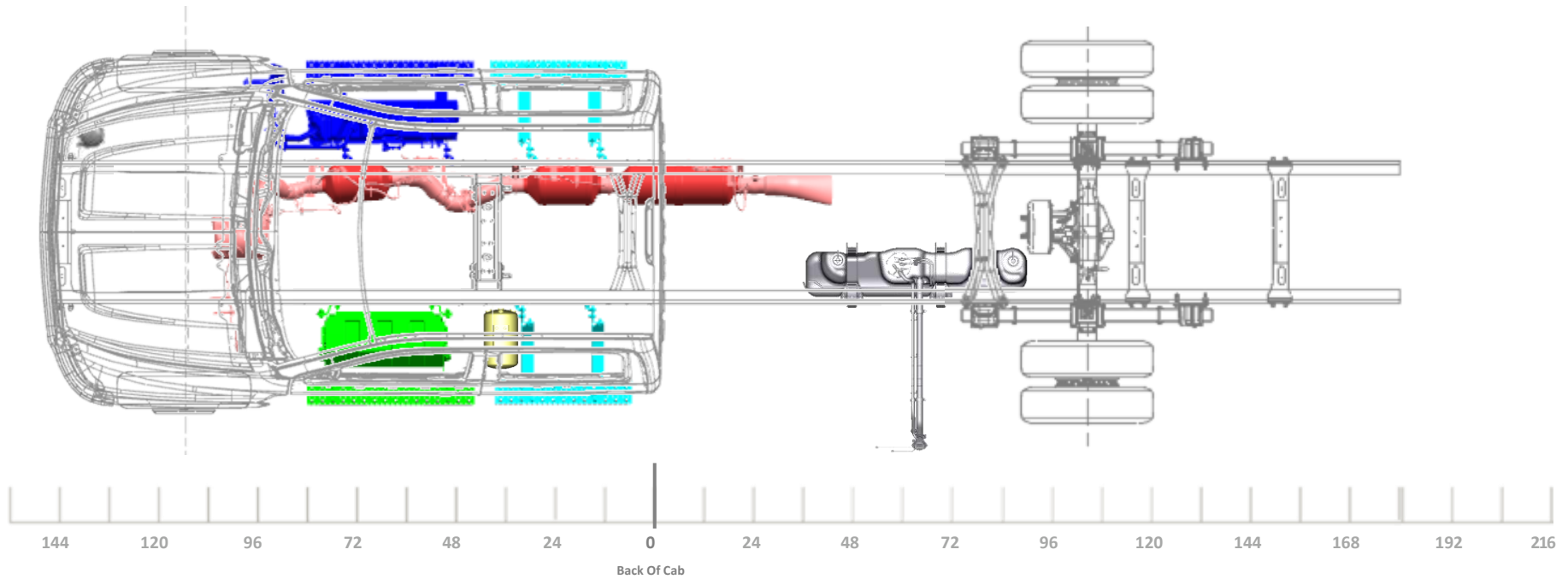

LAST REVISION: 9/28/2023

Model/Feature Information

Model:		C56043 K56043
Cab:		CREW CAB
Aftertreatment:		HORIZONTAL
Fuel Tank:	RPO NVK	25 GAL, CA MTD
Battery Box:	RPO 7Y7/7Y8	28" STEEL, 2 BATTERIES
Air Tanks:		(1) OUTSIDE LEFT
DEF Tank:		6.75 GAL
Engine:		6.6L GM DURAMAX

General Configuration Information

4X2 TRUCK CONFIGURATION
REAR AIR SUSPENSION
STRAIGHT TAILPIPE (RPO N12)
OPTIONAL AIR DRYER FWD OUTSIDE RT (RPO KUT/JPY)

Minimum Wheelbase

219" WB (104" CA)
75" AF

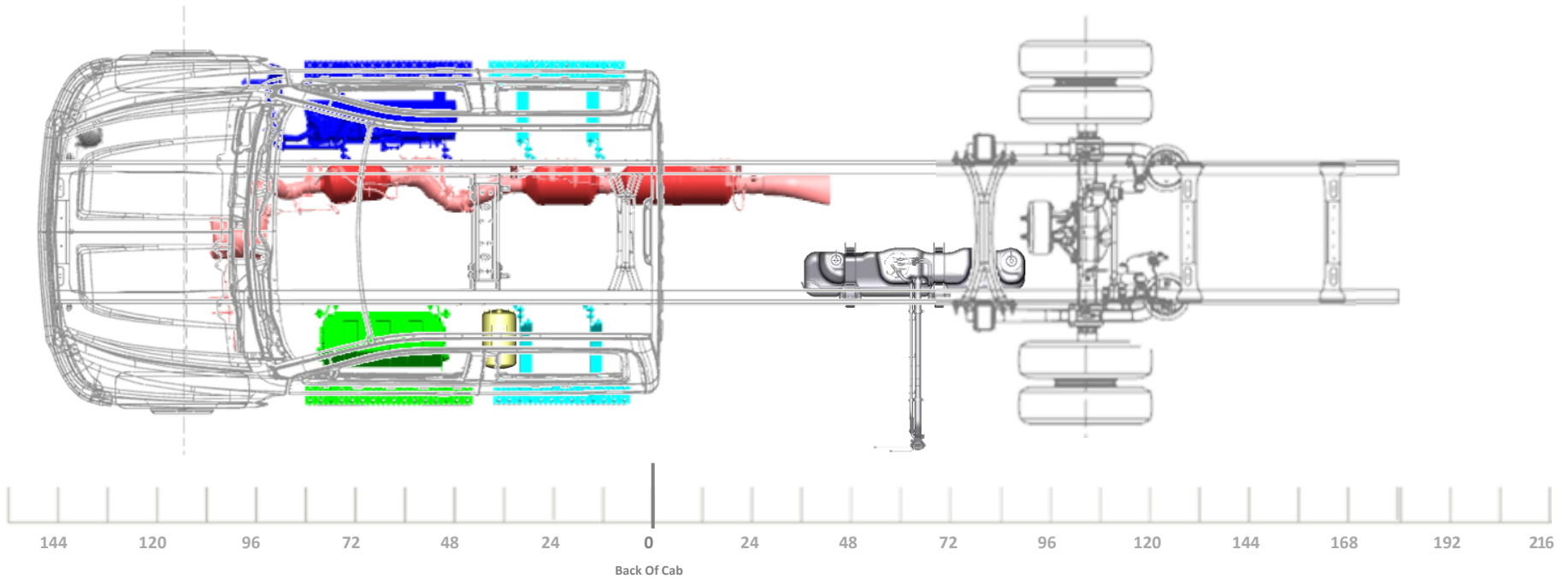

*LAST REVISION: 9/28/2023

Model/Feature Information

Model:		C56043 K56043
Cab:		CREW CAB
Aftertreatment:		HORIZONTAL
Fuel Tank:	RPO NVK	25 GAL, CA MTD
Battery Box:	RPO 7Y9	TEMP MTD, 3 BATT
Air Tanks:		(1) OUTSIDE LEFT
DEF Tank:		6.75 GAL
Engine:		6.6L GM DURAMAX

General Configuration Information

4X2 OR 4X4 TRUCK CONFIGURATION
 VARI-RATE REAR SUSPENSION

STRAIGHT TAILPIPE (RPO N12)

OPTIONAL AIR DRYER FWD OUTSIDE
 RT (RPO KUT/JPY)

Minimum Wheelbase

219" WB (104" CA)
 75" AF

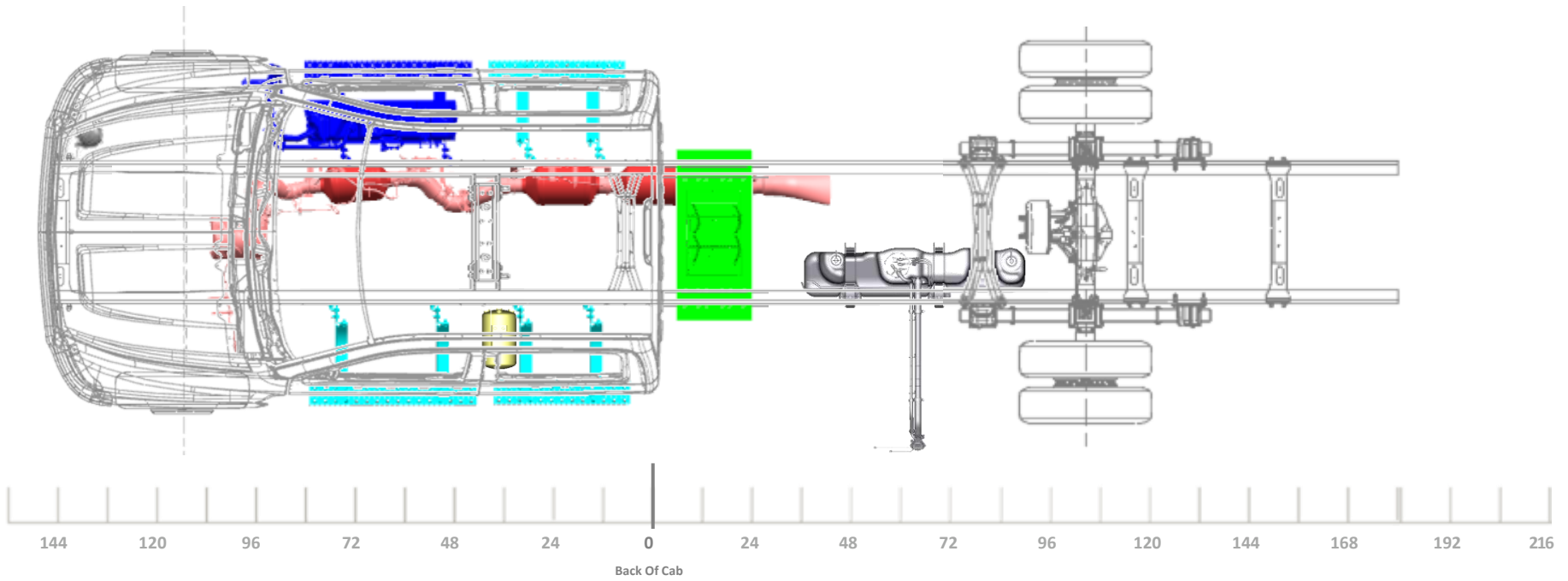

LAST REVISION: 9/28/2023

Model/Feature Information

Model:		C56043 K56043
Cab:		CREW CAB
Aftertreatment:		HORIZONTAL
Fuel Tank:	RPO NVK	25 GAL, CA MTD
Battery Box:	RPO 7Y9	TEMP MTD, 3 BATT
Air Tanks:		(1) OUTSIDE LEFT
DEF Tank:		6.75 GAL
Engine:		6.6L GM DURAMAX

General Configuration Information

4X2 TRUCK CONFIGURATION
REAR AIR SUSPENSION
STRAIGHT TAILPIPE (RPO N12)
OPTIONAL AIR DRYER FWD OUTSIDE RT (RPO KUT/JPY)

Minimum Wheelbase

219" WB (104" CA)
75" AF

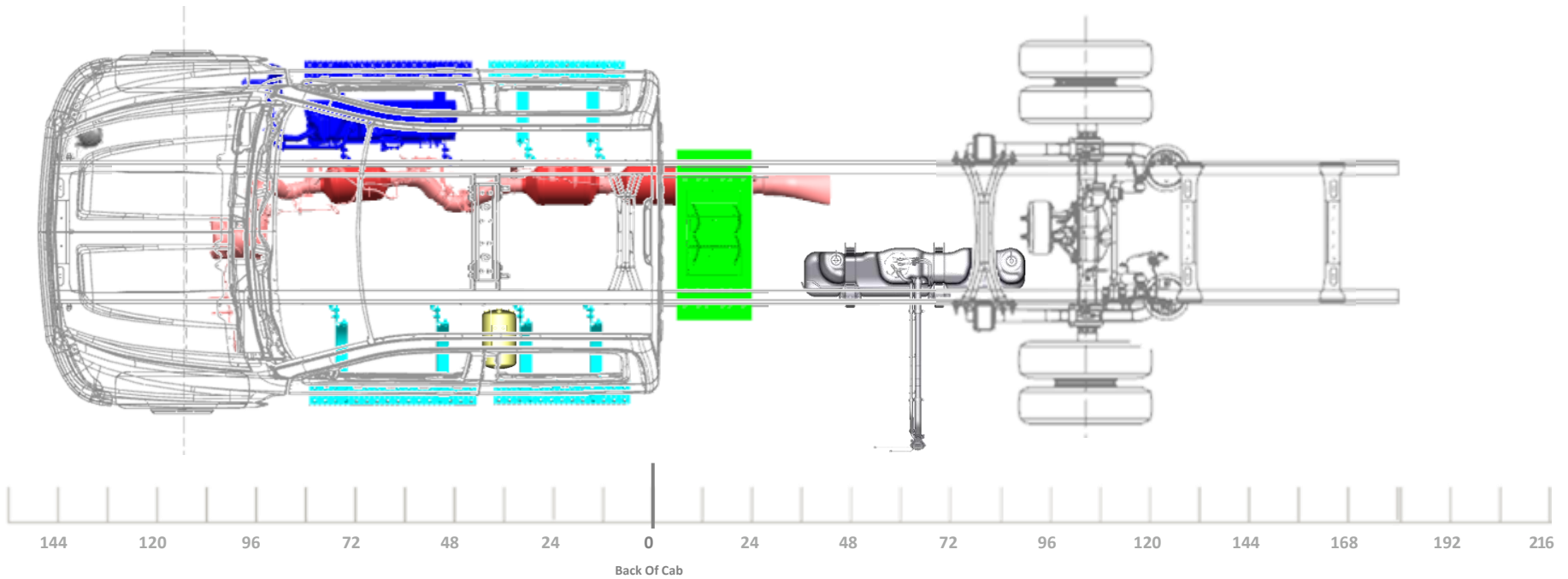

LAST REVISION: 9/28/2023

Model/Feature Information

Model:		C56043 K56043
Cab:		CREW CAB
Aftertreatment:		HORIZONTAL
Fuel Tank:	RPO NVK	25 GAL, CA MTD
Battery Box:	RPO 7Y7/7Y8	28" STEEL, 2 BATTERIES
Air Tanks:		(1) OUTSIDE LEFT
DEF Tank:		6.75 GAL
Engine:		6.6L GM DURAMAX

General Configuration Information

4X2 OR 4X4 TRUCK CONFIGURATION
 VARI-RATE REAR SUSPENSION

SIDE EXIT TAILPIPE AHEAD OF REAR
 WHEELS, RT SIDE (RPO NPK)

OPTIONAL AIR DRYER FWD OUTSIDE
 RT (RPO KUT/JPY)

Minimum Wheelbase

219" WB (104" CA)
 75" AF

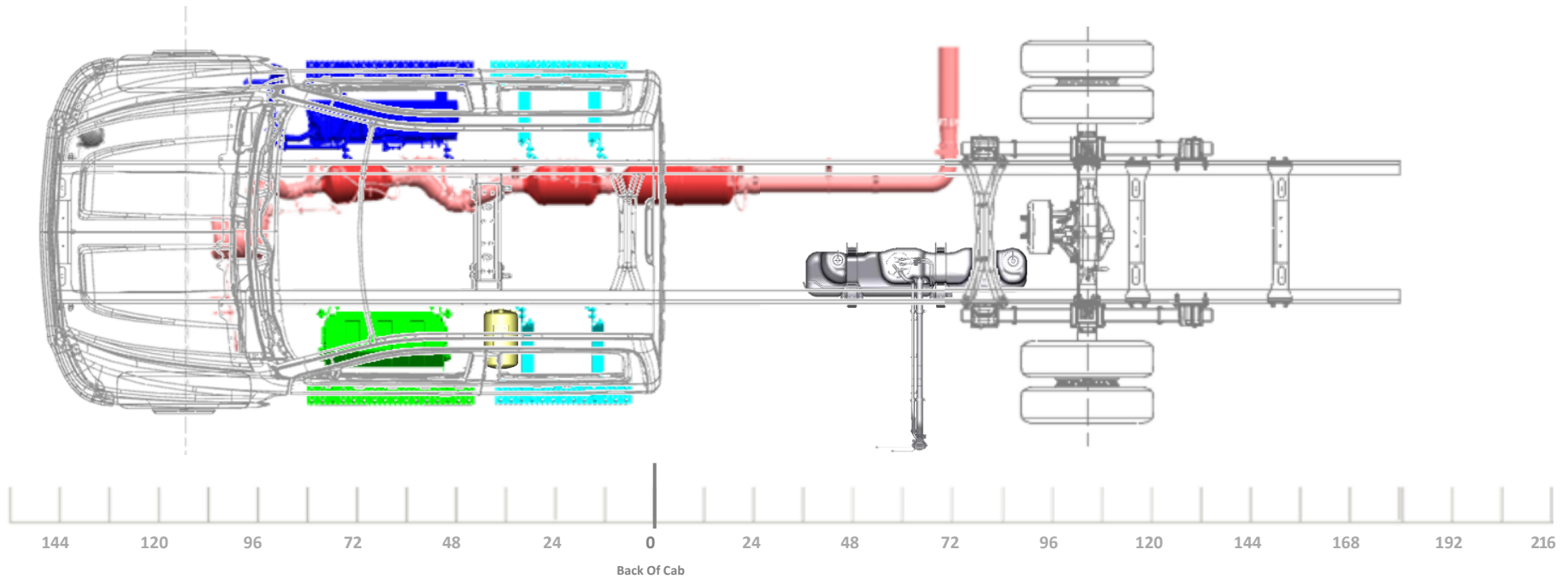

LAST REVISION: 9/28/2023

Model/Feature Information

Model:		C56043 K56043
Cab:		CREW CAB
Aftertreatment:		HORIZONTAL
Fuel Tank:	RPO NVK	25 GAL, CA MTD
Battery Box:	RPO 7Y7/7Y8	28" STEEL, 2 BATTERIES
Air Tanks:		(1) OUTSIDE LEFT
DEF Tank:		6.75 GAL
Engine:		6.6L GM DURAMAX

General Configuration Information

4X2 TRUCK CONFIGURATION
 REAR AIR SUSPENSION
 SIDE EXIT TAILPIPE AHEAD OF REAR WHEELS, RT SIDE (RPO NPK)
 OPTIONAL AIR DRYER FWD OUTSIDE RT (RPO KUT/JPY)

Minimum Wheelbase

219" WB (104" CA)
 75" AF

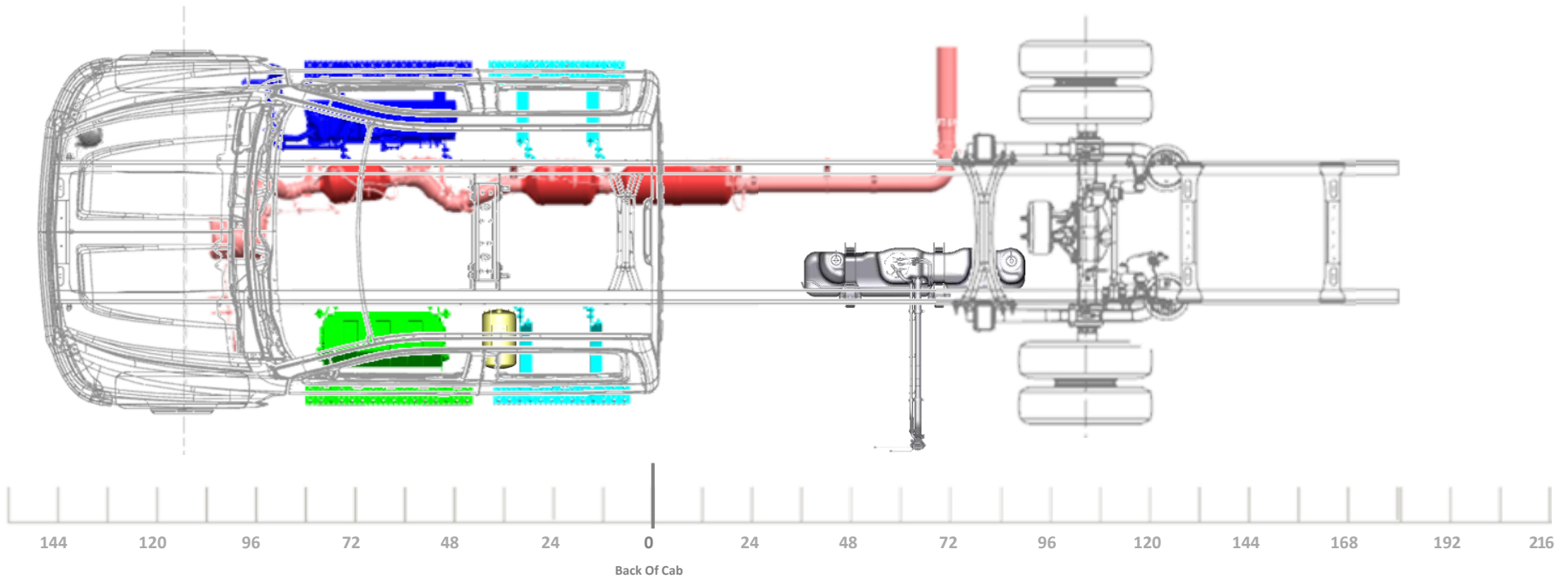

LAST REVISION: 9/28/2023

Model/Feature Information

Model:		C56043 K56043
Cab:		CREW CAB
Aftertreatment:		HORIZONTAL
Fuel Tank:	RPO NVK	25 GAL, CA MTD
Battery Box:	RPO 7Y9	TEMP MTD, 3 BATT
Air Tanks:		(1) OUTSIDE LEFT
DEF Tank:		6.75 GAL
Engine:		6.6L GM DURAMAX

General Configuration Information

4X2 OR 4X4 TRUCK CONFIGURATION
 VARI-RATE REAR SUSPENSION

SIDE EXIT TAILPIPE AHEAD OF REAR
 WHEELS, RT SIDE (RPO NPK)

OPTIONAL AIR DRYER FWD OUTSIDE
 RT (RPO KUT/JPY)

Minimum Wheelbase

219" WB (104" CA)
 75" AF

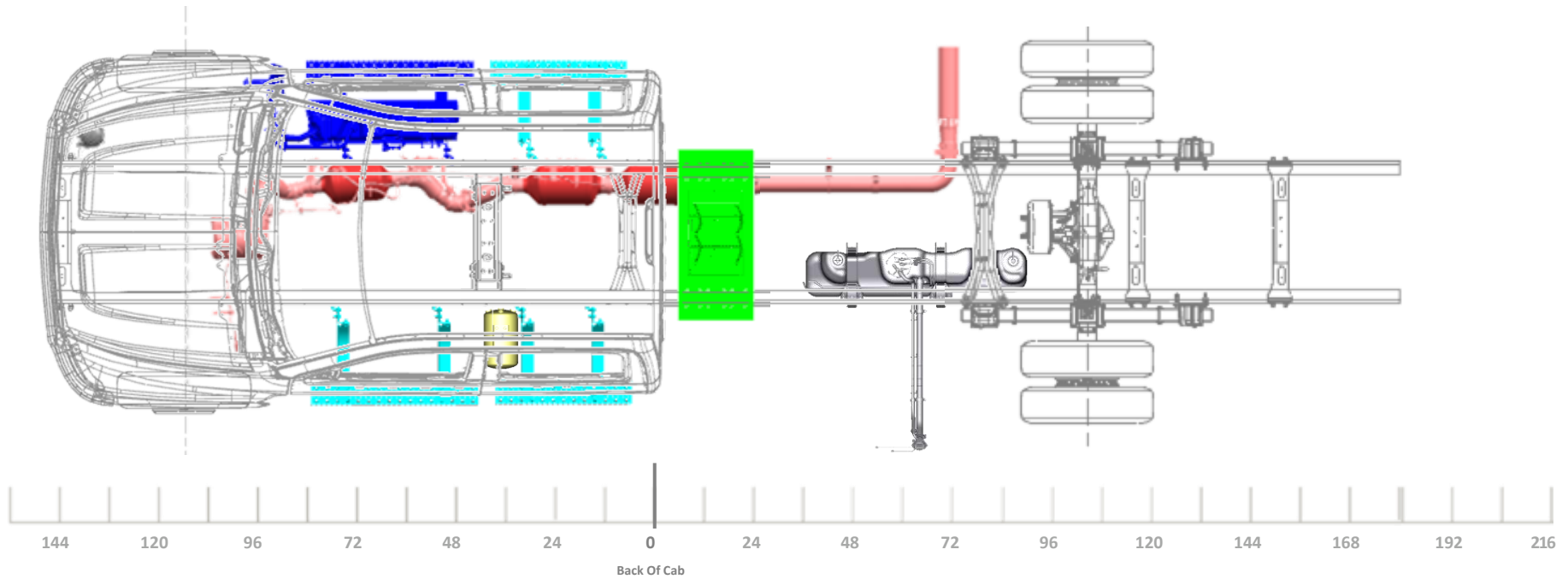

LAST REVISION: 9/28/2023

Model/Feature Information

Model:		C56043 K56043
Cab:		CREW CAB
Aftertreatment:		HORIZONTAL
Fuel Tank:	RPO NVK	25 GAL, CA MTD
Battery Box:	RPO 7Y9	TEMP MTD, 3 BATT
Air Tanks:		(1) OUTSIDE LEFT
DEF Tank:		6.75 GAL
Engine:		6.6L GM DURAMAX

General Configuration Information

4X2 TRUCK CONFIGURATION
 REAR AIR SUSPENSION
 SIDE EXIT TAILPIPE AHEAD OF REAR WHEELS, RT SIDE (RPO NPK)
 OPTIONAL AIR DRYER FWD OUTSIDE RT (RPO KUT/JPY)

Minimum Wheelbase

219" WB (104" CA)
 75" AF

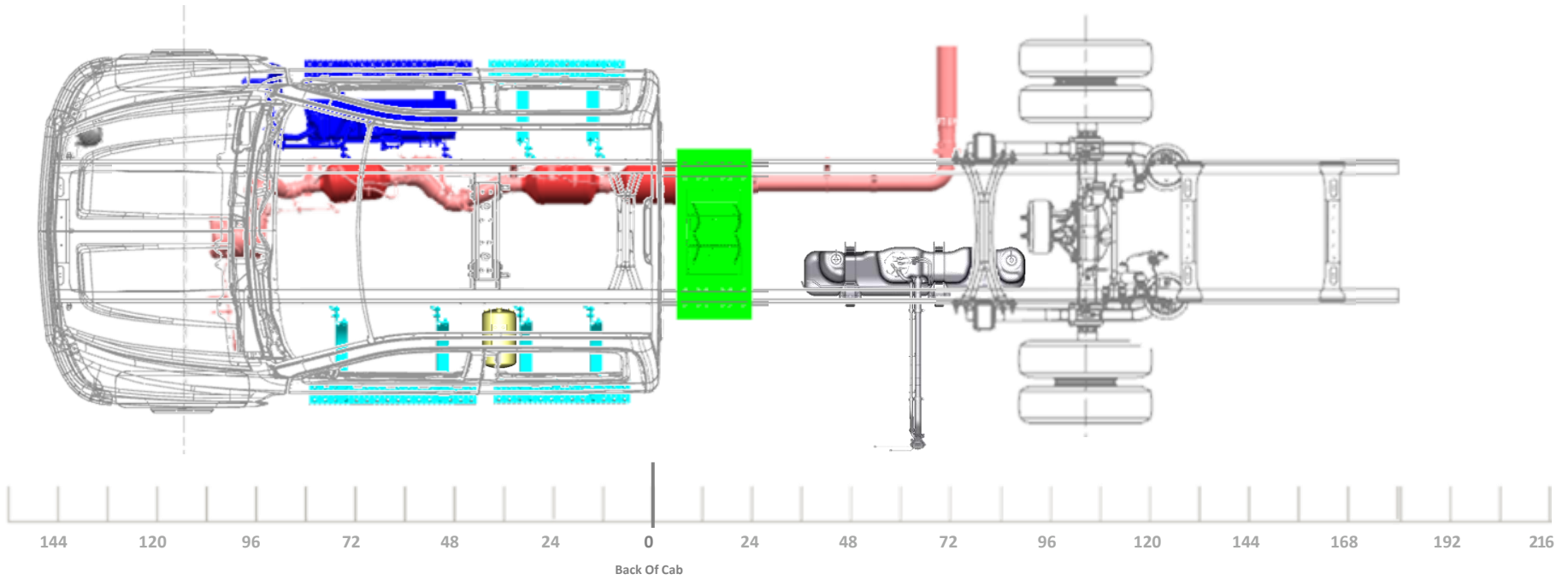

LAST REVISION: 9/28/2023

Model/Feature Information

Model:		C56043 K56043
Cab:		CREW CAB
Aftertreatment:		HORIZONTAL
Fuel Tank:	RPO NSQ	DUAL 25G CA, 40G AF
Battery Box:	RPO 7Y7/7Y8	28" STEEL, 2 BATTERIES
Air Tanks:		(1) OUTSIDE LEFT
DEF Tank:		6.75 GAL
Engine:		6.6L GM DURAMAX

General Configuration Information

4X2 OR 4X4 TRUCK CONFIGURATION
 VARI-RATE REAR SUSPENSION

STRAIGHT TAILPIPE (RPO N12)

OPTIONAL AIR DRYER FWD OUTSIDE
 RT (RPO KUT/JPY)

Minimum Wheelbase

219" WB (104" CA)
 75" AF

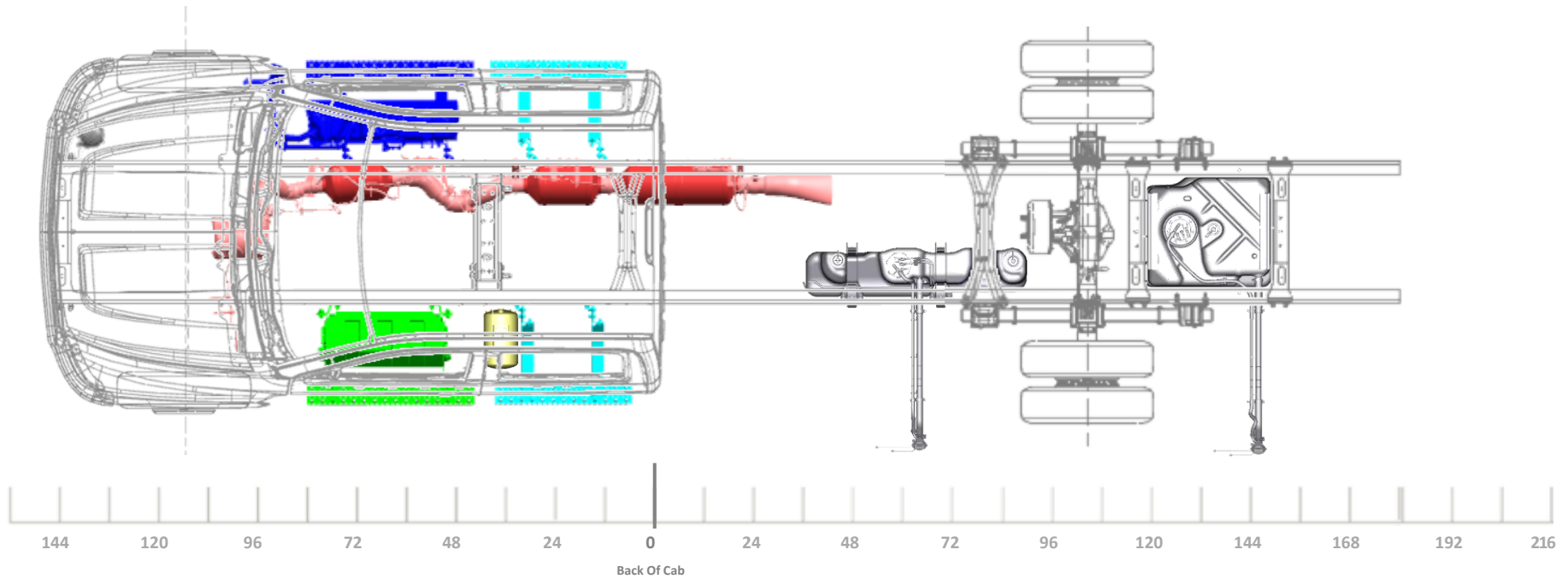

LAST REVISION: 9/28/2023

Model/Feature Information

Model:		C56043 K56043
Cab:		CREW CAB
Aftertreatment:		HORIZONTAL
Fuel Tank:	RPO NSQ	DUAL 25G CA, 40G AF
Battery Box:	RPO 7Y7/7Y8	28" STEEL, 2 BATTERIES
Air Tanks:		(1) OUTSIDE LEFT
DEF Tank:		6.75 GAL
Engine:		6.6L GM DURAMAX

General Configuration Information

4X2 TRUCK CONFIGURATION
REAR AIR SUSPENSION
STRAIGHT TAILPIPE (RPO N12)
OPTIONAL AIR DRYER FWD OUTSIDE RT (RPO KUT/JPY)

Minimum Wheelbase

219" WB (104" CA)
75" AF

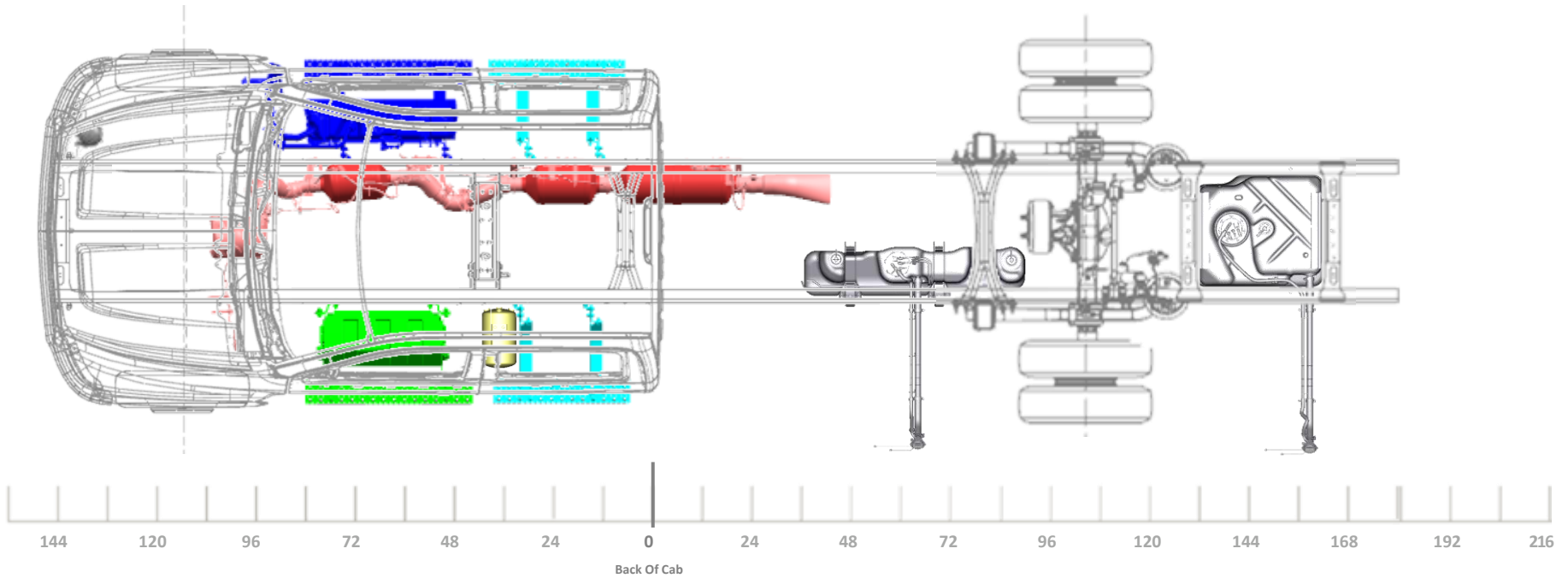

LAST REVISION: 9/28/2023

Model/Feature Information

Model:		C56043 K56043
Cab:		CREW CAB
Aftertreatment:		HORIZONTAL
Fuel Tank:	RPO NSQ	DUAL 25G CA, 40G AF
Battery Box:	RPO 7Y9	TEMP MTD, 3 BATT
Air Tanks:		(1) OUTSIDE LEFT
DEF Tank:		6.75 GAL
Engine:		6.6L GM DURAMAX

General Configuration Information

4X2 OR 4X4 TRUCK CONFIGURATION
VARI-RATE REAR SUSPENSION

STRAIGHT TAILPIPE (RPO N12)

OPTIONAL AIR DRYER FWD OUTSIDE
RT (RPO KUT/JPY)

Minimum Wheelbase

219" WB (104" CA)
75" AF

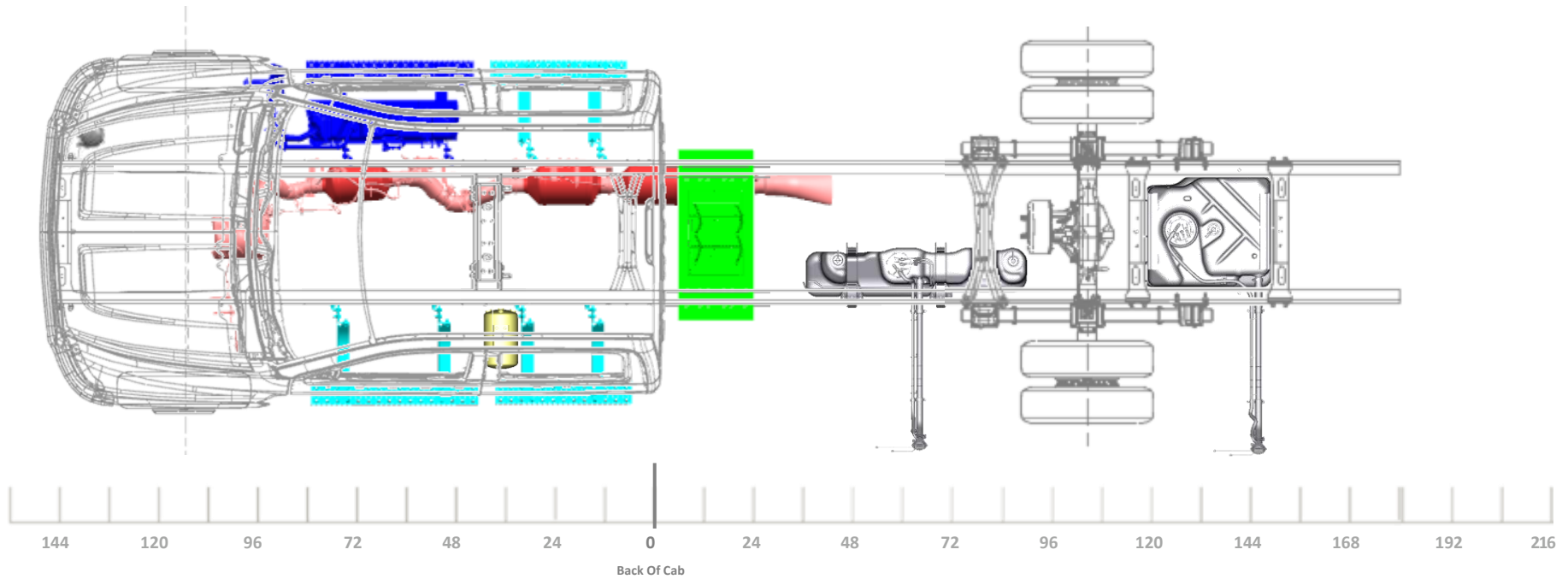

LAST REVISION: 9/28/2023

Model/Feature Information

Model:		C56043 K56043
Cab:		CREW CAB
Aftertreatment:		HORIZONTAL
Fuel Tank:	RPO NSQ	DUAL 25G CA, 40G AF
Battery Box:	RPO 7Y9	TEMP MTD, 3 BATT
Air Tanks:		(1) OUTSIDE LEFT
DEF Tank:		6.75 GAL
Engine:		6.6L GM DURAMAX

General Configuration Information

4X2 TRUCK CONFIGURATION
REAR AIR SUSPENSION
STRAIGHT TAILPIPE (RPO N12)
OPTIONAL AIR DRYER FWD OUTSIDE RT (RPO KUT/JPY)

Minimum Wheelbase

219" WB (104" CA)
75" AF

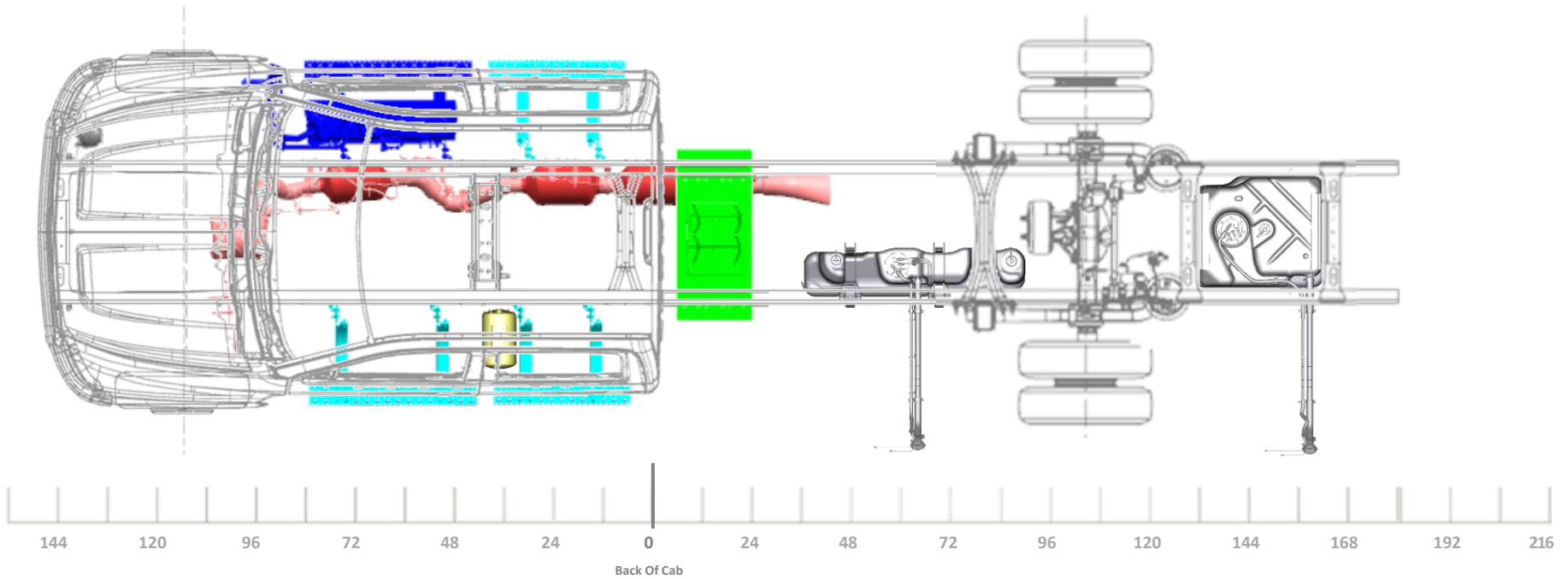

LAST REVISION: 9/28/2023

Model/Feature Information

Model:		C56043 K56043
Cab:		CREW CAB
Aftertreatment:		HORIZONTAL
Fuel Tank:	RPO NSQ	DUAL 25G CA, 40G AF
Battery Box:	RPO 7Y7/7Y8	28" STEEL, 2 BATTERIES
Air Tanks:		(1) OUTSIDE LEFT
DEF Tank:		6.75 GAL
Engine:		6.6L GM DURAMAX

General Configuration Information

4X2 OR 4X4 TRUCK CONFIGURATION
 VARI-RATE REAR SUSPENSION

SIDE EXIT TAILPIPE AHEAD OF REAR
 WHEELS, RT SIDE (RPO NPK)

OPTIONAL AIR DRYER FWD OUTSIDE
 RT (RPO KUT/JPY)

Minimum Wheelbase

219" WB (104" CA)
 75" AF

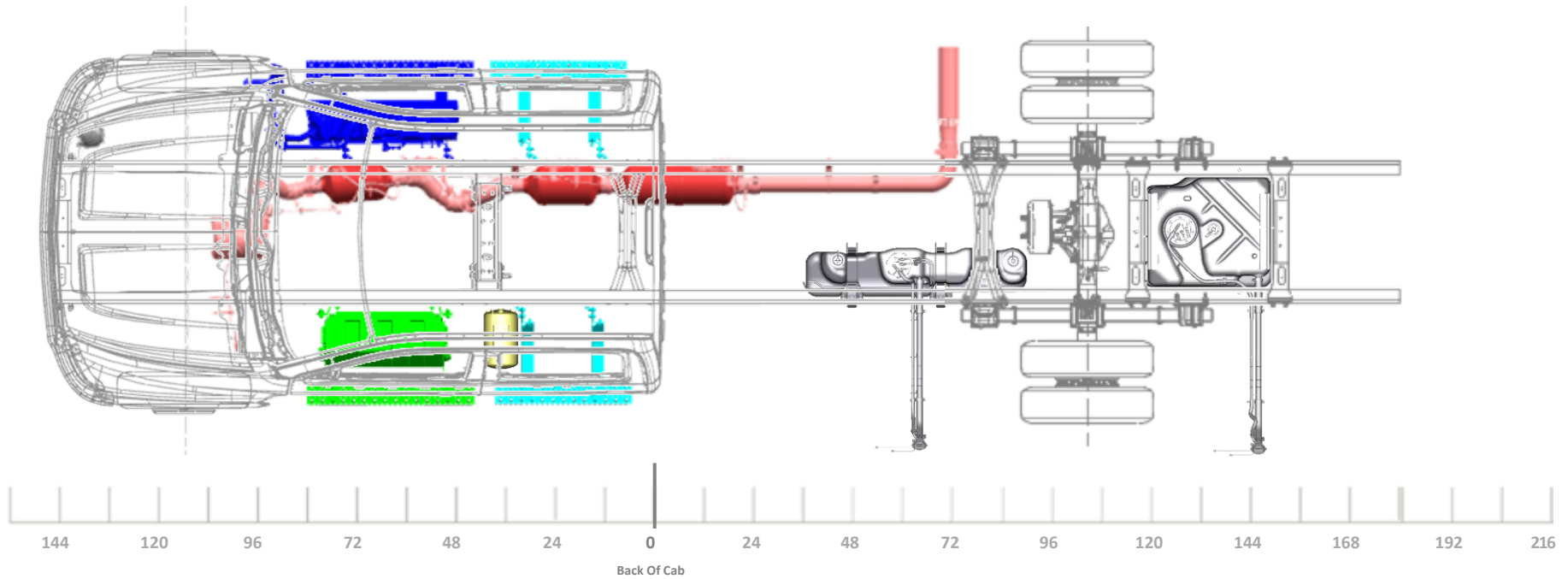

LAST REVISION: 9/28/2023

Model/Feature Information

Model:		C56043 K56043
Cab:		CREW CAB
Aftertreatment:		HORIZONTAL
Fuel Tank:	RPO NSQ	DUAL 25G CA, 40G AF
Battery Box:	RPO 7Y7/7Y8	28" STEEL, 2 BATTERIES
Air Tanks:		(1) OUTSIDE LEFT
DEF Tank:		6.75 GAL
Engine:		6.6L GM DURAMAX

General Configuration Information

4X2 TRUCK CONFIGURATION
 REAR AIR SUSPENSION
 SIDE EXIT TAILPIPE AHEAD OF REAR WHEELS, RT SIDE (RPO NPK)
 OPTIONAL AIR DRYER FWD OUTSIDE RT (RPO KUT/JPY)

Minimum Wheelbase

219" WB (104" CA)
 75" AF

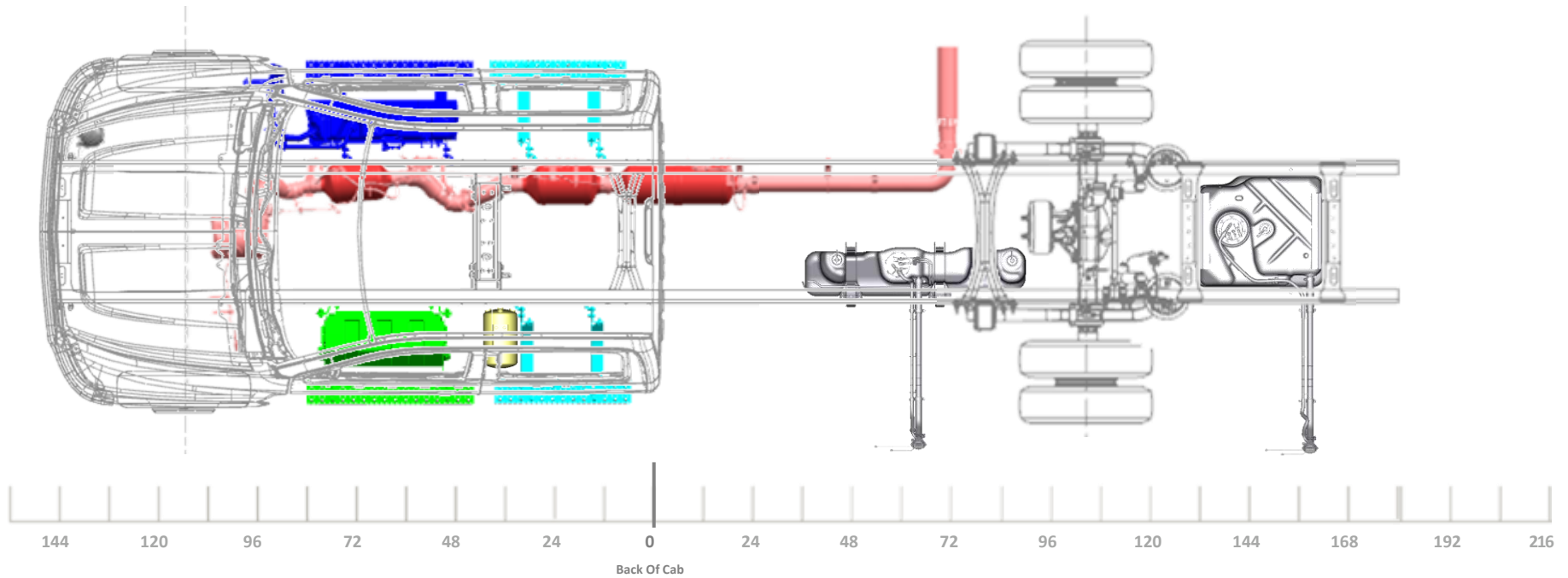

LAST REVISION: 9/28/2023

Model/Feature Information

Model:		C56043 K56043
Cab:		CREW CAB
Aftertreatment:		HORIZONTAL
Fuel Tank:	RPO NSQ	DUAL 25G CA, 40G AF
Battery Box:	RPO 7Y9	TEMP MTD, 3 BATT
Air Tanks:		(1) OUTSIDE LEFT
DEF Tank:		6.75 GAL
Engine:		6.6L GM DURAMAX

General Configuration Information

4X2 OR 4X4 TRUCK CONFIGURATION
 VARI-RATE REAR SUSPENSION

SIDE EXIT TAILPIPE AHEAD OF REAR
 WHEELS, RT SIDE (RPO NPK)

OPTIONAL AIR DRYER FWD OUTSIDE
 RT (RPO KUT/JPY)

Minimum Wheelbase

219" WB (104" CA)
 75" AF

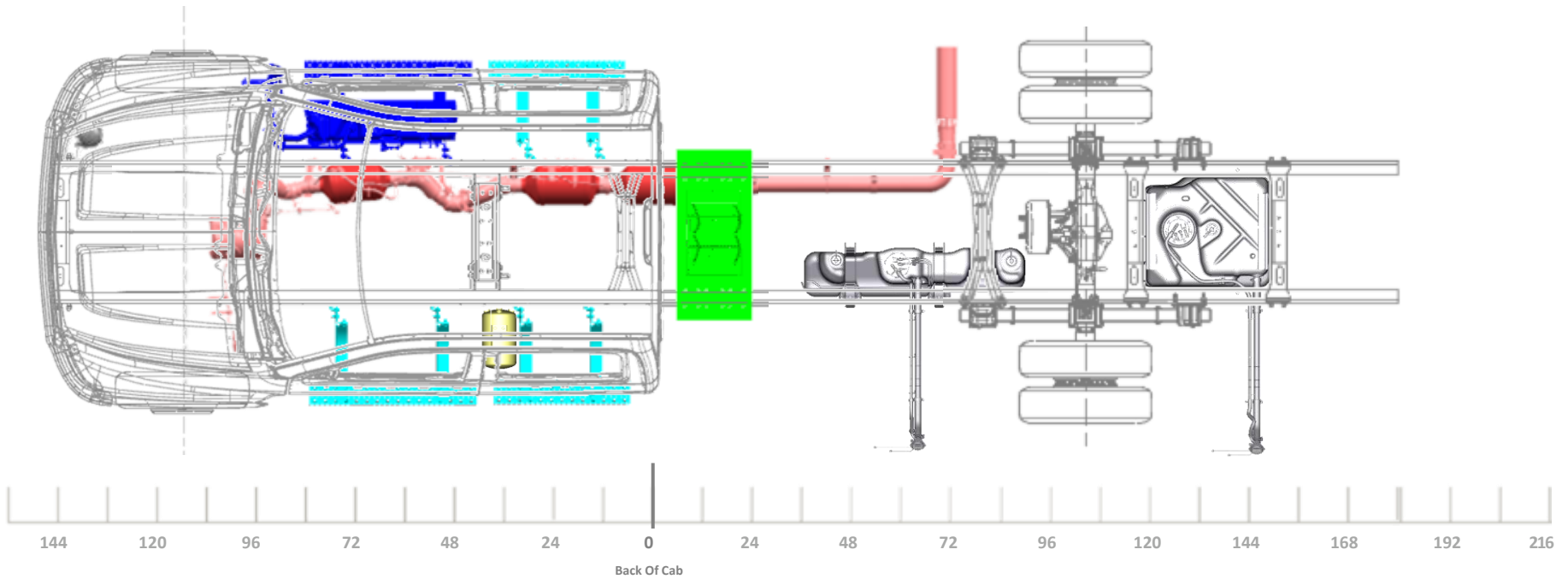

LAST REVISION: 9/28/2023

Model/Feature Information

Model:		C56043 K56043
Cab:		CREW CAB
Aftertreatment:		HORIZONTAL
Fuel Tank:	RPO NSQ	DUAL 25G CA, 40G AF
Battery Box:	RPO 7Y9	TEMP MTD, 3 BATT
Air Tanks:		(1) OUTSIDE LEFT
DEF Tank:		6.75 GAL
Engine:		6.6L GM DURAMAX

General Configuration Information

4X2 TRUCK CONFIGURATION
 REAR AIR SUSPENSION

SIDE EXIT TAILPIPE AHEAD OF REAR WHEELS, RT SIDE (RPO NPK)

OPTIONAL AIR DRYER FWD OUTSIDE RT (RPO KUT/JPY)

Minimum Wheelbase

219" WB (104" CA)
 75" AF

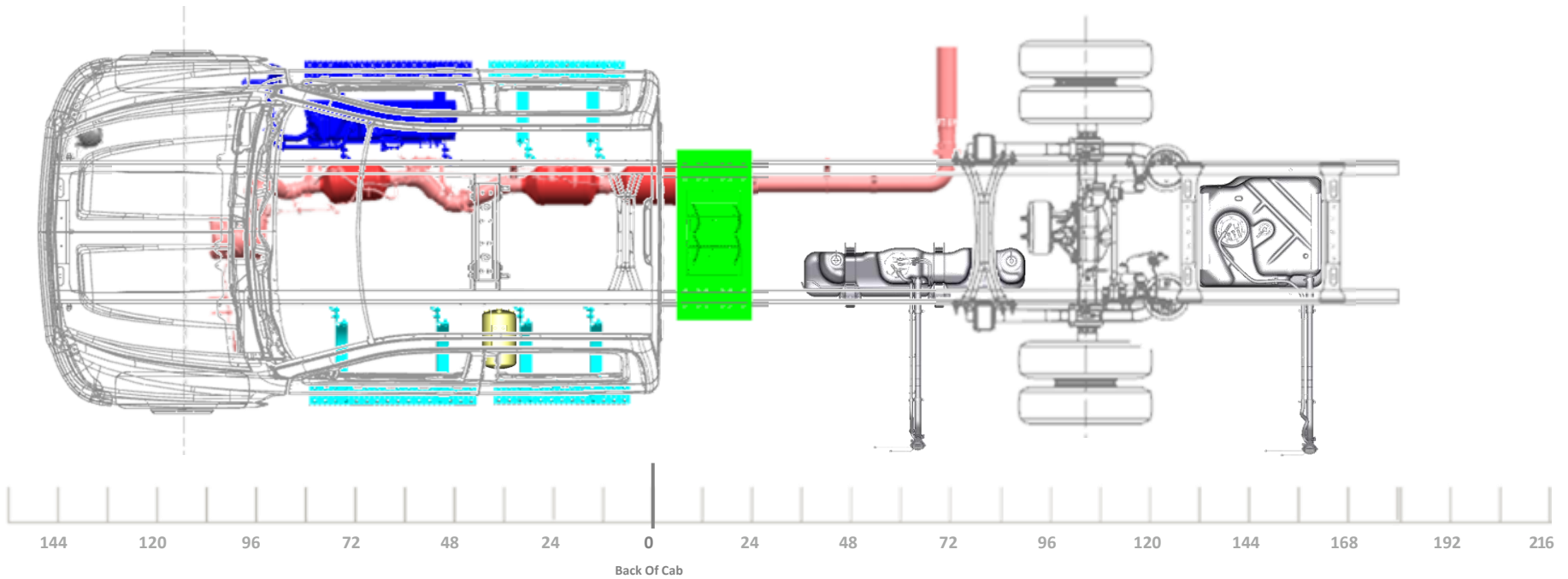

LAST REVISION: 9/28/2023

CREW CAB
235" WB

Model/Feature Information

Model:		C56043 K56043
Cab:		CREW CAB
Aftertreatment:		HORIZONTAL
Fuel Tank:	RPO N2L	40 GAL, AF MTD
Battery Box:	RPO 7Y7/7Y8	28" STEEL, 2 BATTERIES
Air Tanks:		(1) OUTSIDE LEFT
DEF Tank:		6.75 GAL
Engine:		6.6L GM DURAMAX

General Configuration Information

4X2 OR 4X4 TRUCK CONFIGURATION
 VARI-RATE REAR SUSPENSION

STRAIGHT TAILPIPE (RPO N12)

OPTIONAL AIR DRYER FWD OUTSIDE
 RT (RPO KUT/JPY)

Minimum Wheelbase

235" WB (120" CA)
 75" AF

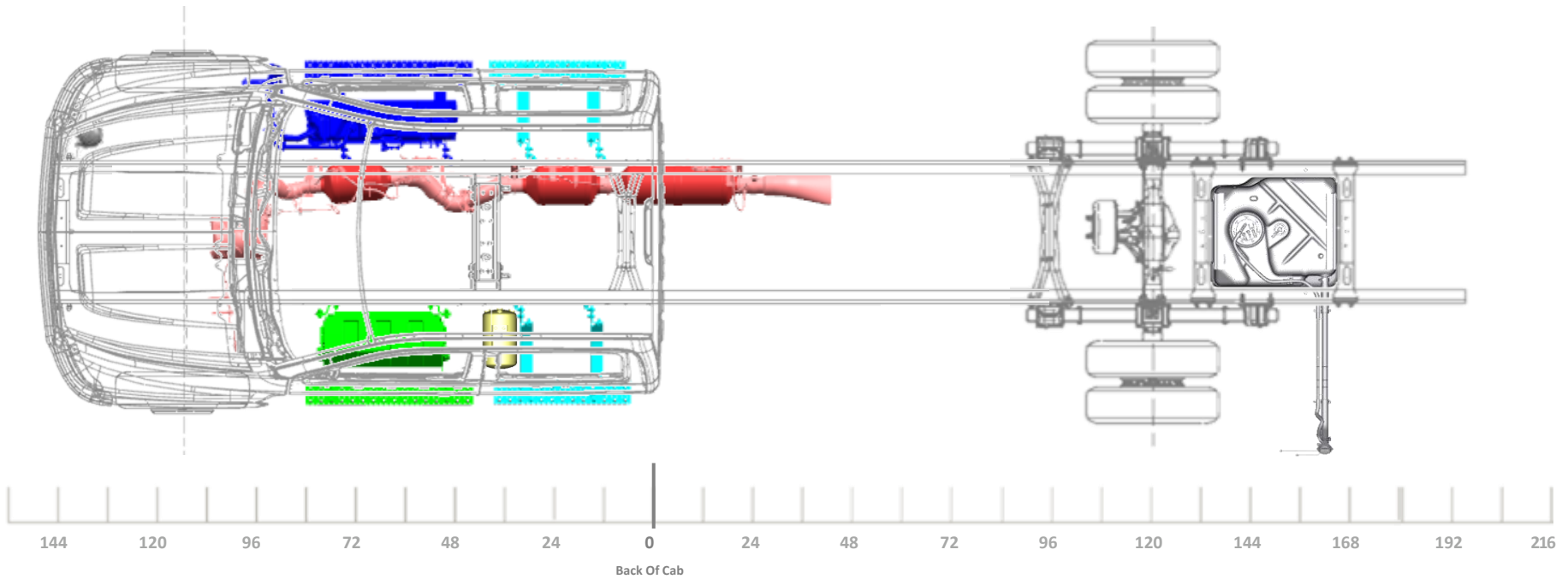

LAST REVISION: 9/28/2023

Model/Feature Information

Model:		C56043 K56043
Cab:		CREW CAB
Aftertreatment:		HORIZONTAL
Fuel Tank:	RPO N2L	40 GAL, AF MTD
Battery Box:	RPO 7Y7/7Y8	28" STEEL, 2 BATTERIES
Air Tanks:		(1) OUTSIDE LEFT
DEF Tank:		6.75 GAL
Engine:		6.6L GM DURAMAX

General Configuration Information

4X2 TRUCK CONFIGURATION
REAR AIR SUSPENSION
STRAIGHT TAILPIPE (RPO N12)
OPTIONAL AIR DRYER FWD OUTSIDE RT (RPO KUT/JPY)

Minimum Wheelbase

235" WB (120" CA)
75" AF

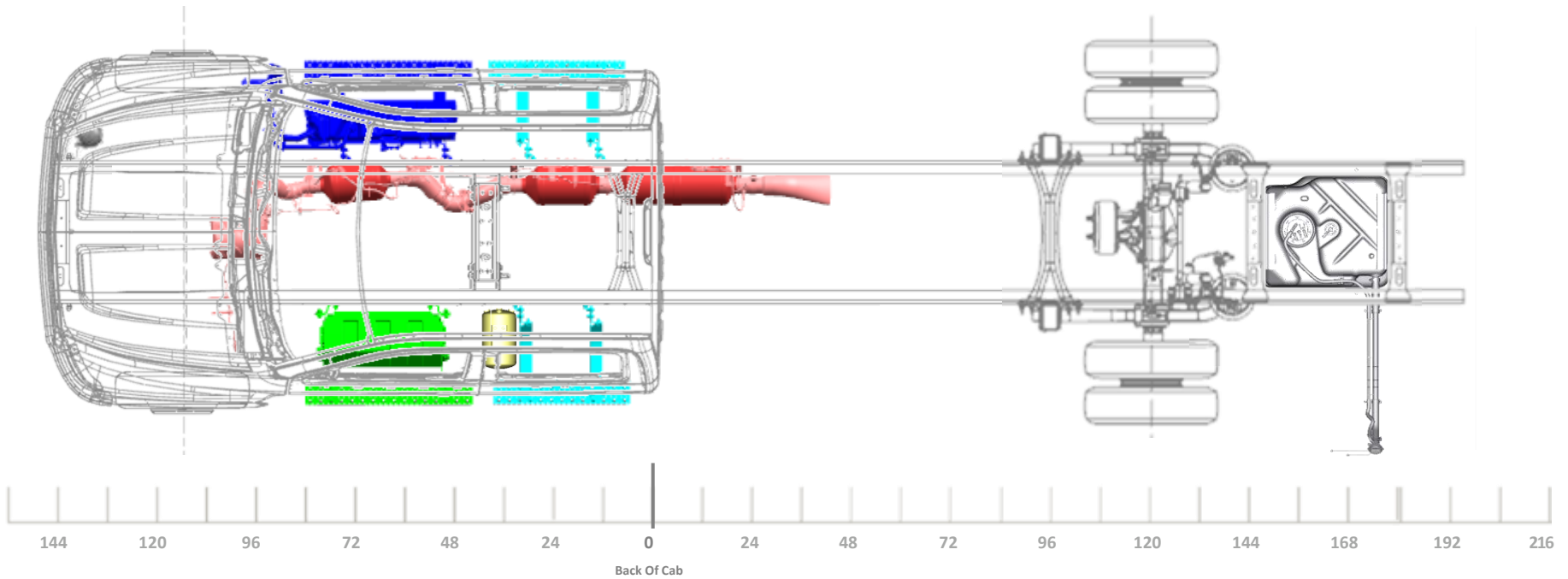

AST REVISION: 9/28/2023

Model/Feature Information

Model:		C56043 K56043
Cab:		CREW CAB
Aftertreatment:		HORIZONTAL
Fuel Tank:	RPO N2L	40 GAL, AF MTD
Battery Box:	RPO 7Y9	TEMP MTD, 3 BATT
Air Tanks:		(1) OUTSIDE LEFT
DEF Tank:		6.75 GAL
Engine:		6.6L GM DURAMAX

General Configuration Information

4X2 OR 4X4 TRUCK CONFIGURATION
 VARI-RATE REAR SUSPENSION

STRAIGHT TAILPIPE (RPO N12)

OPTIONAL AIR DRYER FWD OUTSIDE
 RT (RPO KUT/JPY)

Minimum Wheelbase

235" WB (120" CA)
 75" AF

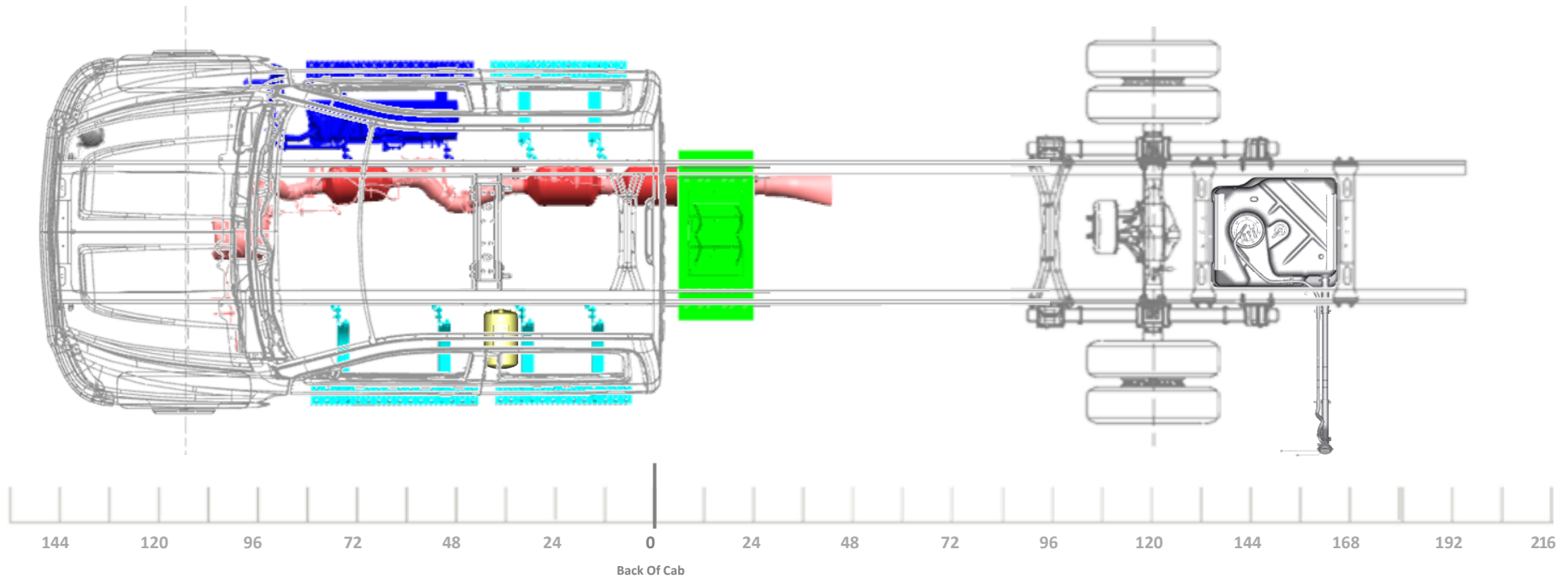

LAST REVISION: 9/28/2023

Model/Feature Information

Model:		C56043 K56043
Cab:		CREW CAB
Aftertreatment:		HORIZONTAL
Fuel Tank:	RPO N2L	40 GAL, AF MTD
Battery Box:	RPO 7Y9	TEMP MTD, 3 BATT
Air Tanks:		(1) OUTSIDE LEFT
DEF Tank:		6.75 GAL
Engine:		6.6L GM DURAMAX

General Configuration Information

4X2 TRUCK CONFIGURATION
REAR AIR SUSPENSION
STRAIGHT TAILPIPE (RPO N12)
OPTIONAL AIR DRYER FWD OUTSIDE RT (RPO KUT/JPY)

Minimum Wheelbase

235" WB (120" CA)
75" AF

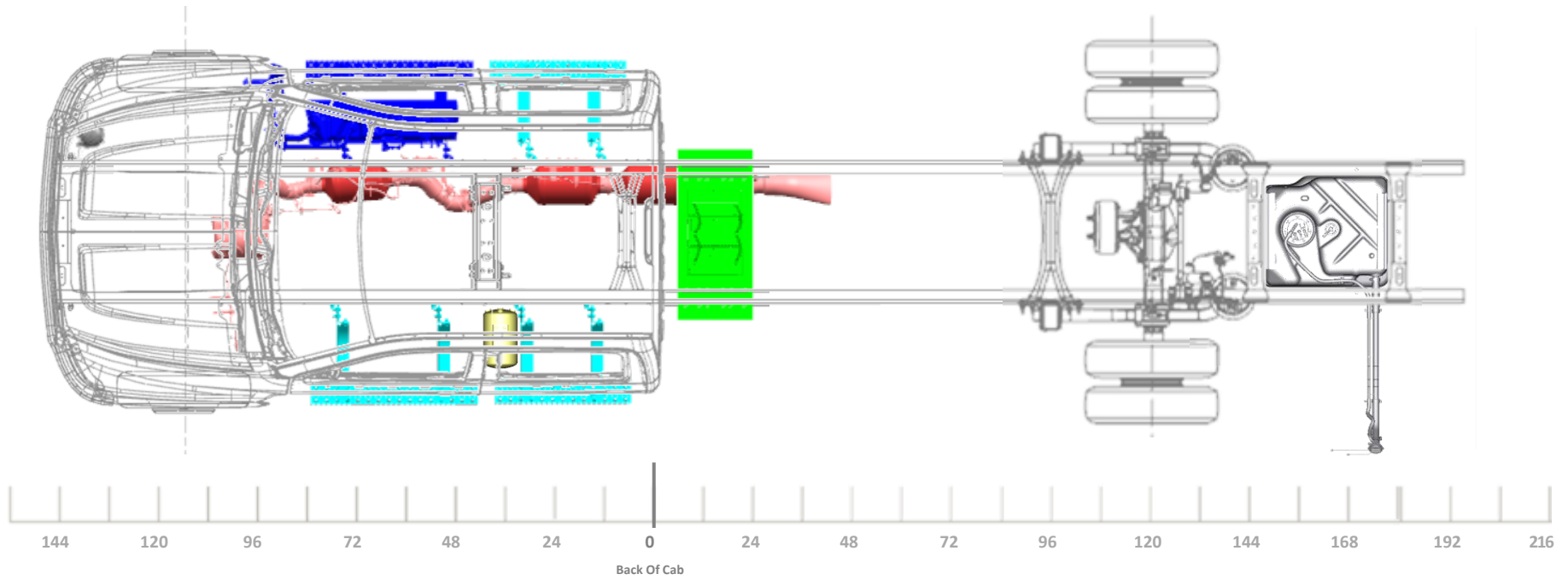

LAST REVISION: 9/28/2023

Model/Feature Information

Model:		C56043 K56043
Cab:		CREW CAB
Aftertreatment:		HORIZONTAL
Fuel Tank:	RPO N2L	40 GAL, AF MTD
Battery Box:	RPO 7Y7/7Y8	28" STEEL, 2 BATTERIES
Air Tanks:		(1) OUTSIDE LEFT
DEF Tank:		6.75 GAL
Engine:		6.6L GM DURAMAX

General Configuration Information

4X2 OR 4X4 TRUCK CONFIGURATION
 VARI-RATE REAR SUSPENSION

SIDE EXIT TAILPIPE AHEAD OF REAR
 WHEELS, LT SIDE (RPO NPJ)

OPTIONAL AIR DRYER FWD OUTSIDE
 RT (RPO KUT/JPY)

Minimum Wheelbase

235" WB (120" CA)
 75" AF

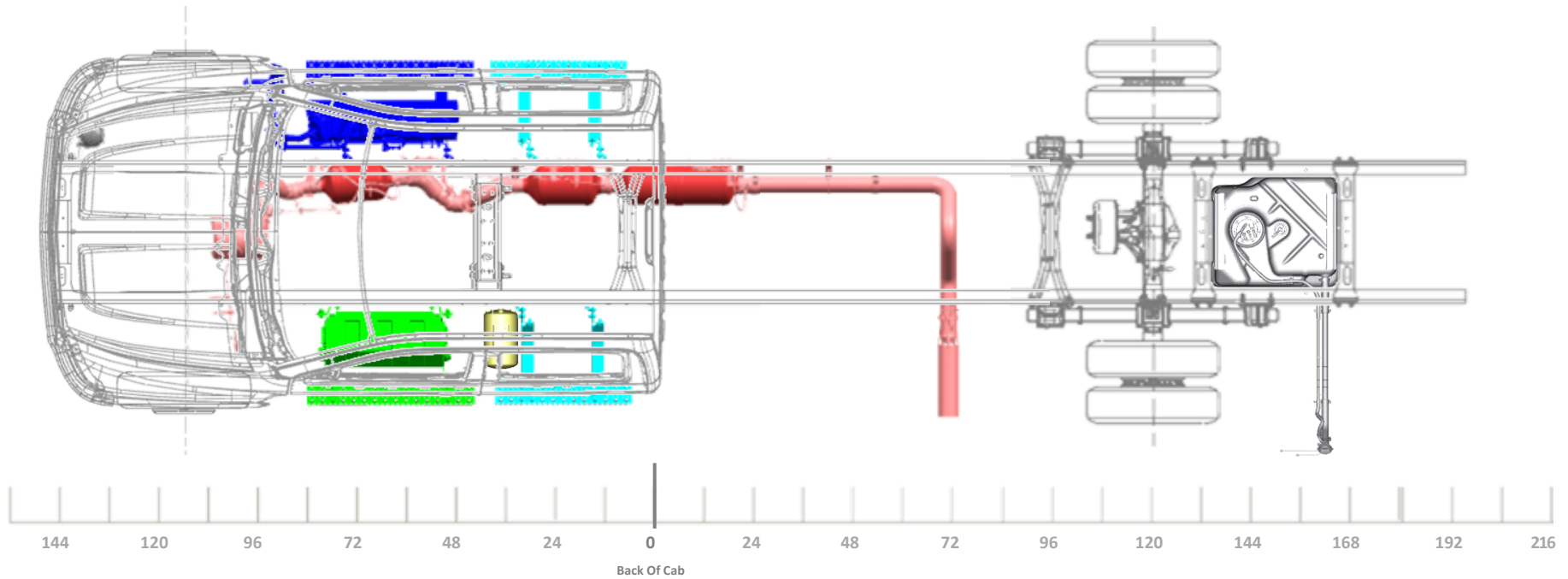

LAST REVISION: 9/28/2023

Model/Feature Information

Model:		C56043 K56043
Cab:		CREW CAB
Aftertreatment:		HORIZONTAL
Fuel Tank:	RPO N2L	40 GAL, AF MTD
Battery Box:	RPO 7Y7/7Y8	28" STEEL, 2 BATTERIES
Air Tanks:		(1) OUTSIDE LEFT
DEF Tank:		6.75 GAL
Engine:		6.6L GM DURAMAX

General Configuration Information

4X2 TRUCK CONFIGURATION
REAR AIR SUSPENSION
SIDE EXIT TAILPIPE AHEAD OF REAR WHEELS, LT SIDE (RPO NPJ)
OPTIONAL AIR DRYER FWD OUTSIDE RT (RPO KUT/JPY)

Minimum Wheelbase

235" WB (120" CA)
75" AF

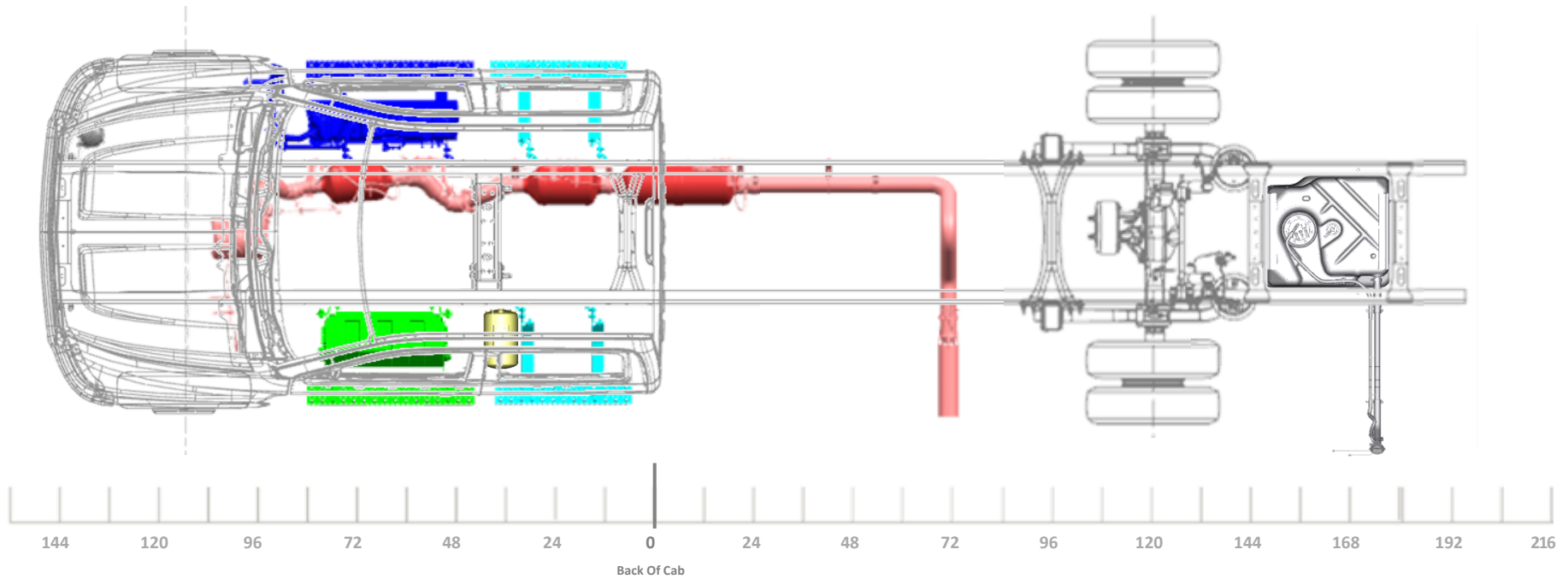

LAST REVISION: 9/28/2023

Model/Feature Information

Model:		C56043 K56043
Cab:		CREW CAB
Aftertreatment:		HORIZONTAL
Fuel Tank:	RPO N2L	40 GAL, AF MTD
Battery Box:	RPO 7Y9	TEMP MTD, 3 BATT
Air Tanks:		(1) OUTSIDE LEFT
DEF Tank:		6.75 GAL
Engine:		6.6L GM DURAMAX

General Configuration Information

4X2 OR 4X4 TRUCK CONFIGURATION
 VARI-RATE REAR SUSPENSION

SIDE EXIT TAILPIPE AHEAD OF REAR
 WHEELS, LT SIDE (RPO NPJ)

OPTIONAL AIR DRYER FWD OUTSIDE
 RT (RPO KUT/JPY)

Minimum Wheelbase

235" WB (120" CA)
 75" AF

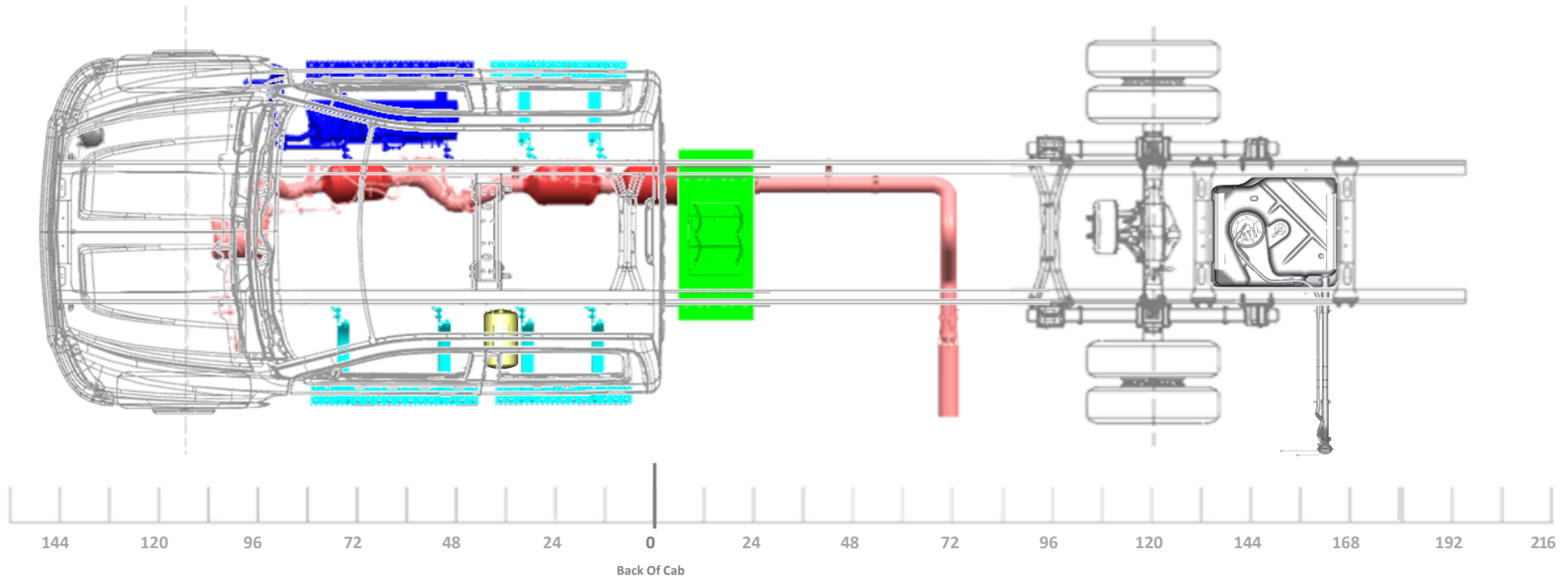

LAST REVISION: 9/28/2023

Model/Feature Information

Model:		C56043 K56043
Cab:		CREW CAB
Aftertreatment:		HORIZONTAL
Fuel Tank:	RPO N2L	40 GAL, AF MTD
Battery Box:	RPO 7Y9	TEMP MTD, 3 BATT
Air Tanks:		(1) OUTSIDE LEFT
DEF Tank:		6.75 GAL
Engine:		6.6L GM DURAMAX

General Configuration Information

4X2 TRUCK CONFIGURATION
 REAR AIR SUSPENSION
 SIDE EXIT TAILPIPE AHEAD OF REAR WHEELS, LT SIDE (RPO NPJ)
 OPTIONAL AIR DRYER FWD OUTSIDE RT (RPO KUT/JPY)

Minimum Wheelbase

235" WB (120" CA)
 75" AF

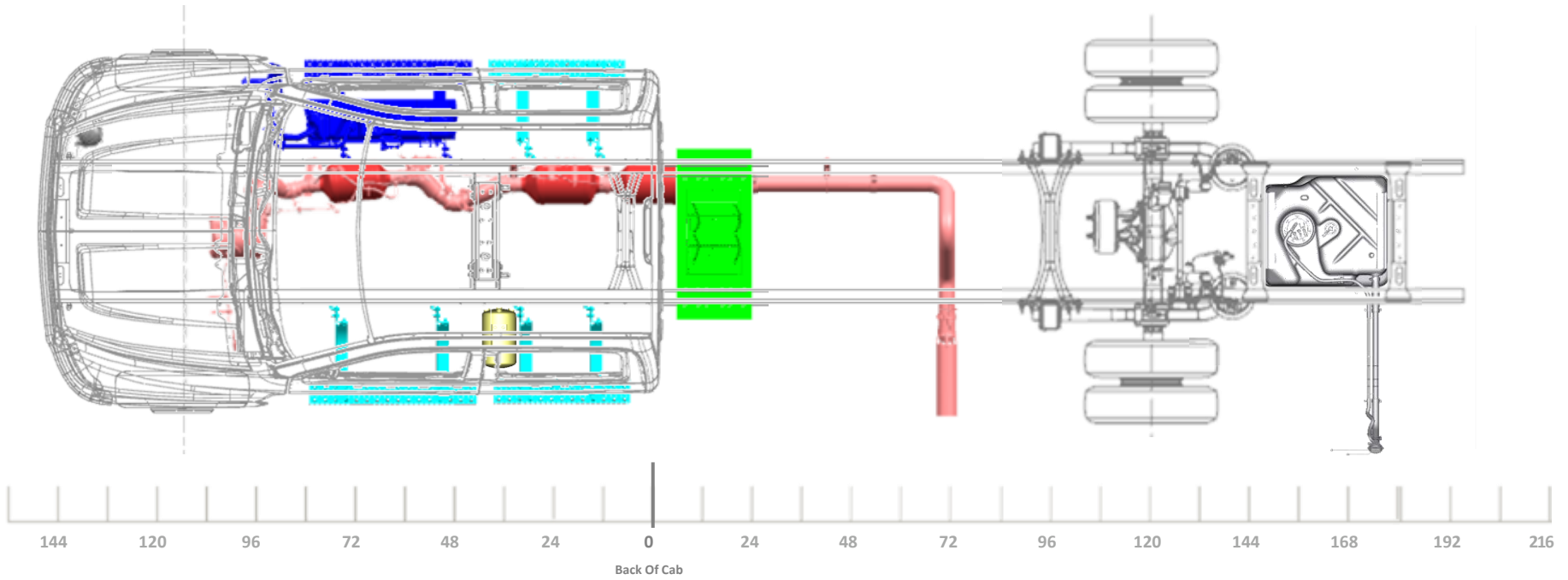

LAST REVISION: 9/28/2023

Model/Feature Information

Model:		C56043 K56043
Cab:		CREW CAB
Aftertreatment:		HORIZONTAL
Fuel Tank:	RPO N2L	40 GAL, AF MTD
Battery Box:	RPO 7Y7/7Y8	28" STEEL, 2 BATTERIES
Air Tanks:		(1) OUTSIDE LEFT
DEF Tank:		6.75 GAL
Engine:		6.6L GM DURAMAX

General Configuration Information

4X2 OR 4X4 TRUCK CONFIGURATION
 VARI-RATE REAR SUSPENSION

SIDE EXIT TAILPIPE AHEAD OF REAR
 WHEELS, RT SIDE (RPO NPK)

OPTIONAL AIR DRYER FWD OUTSIDE
 RT (RPO KUT/JPY)

Minimum Wheelbase

235" WB (120" CA)
 75" AF

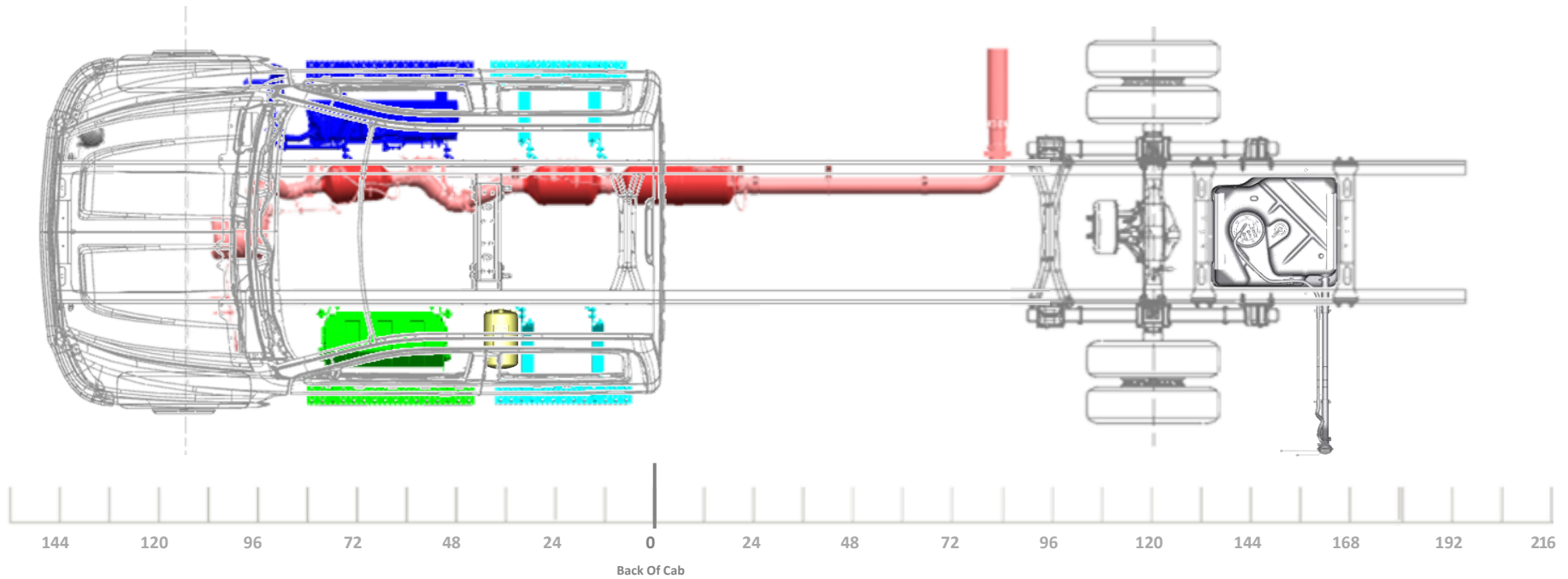

LAST REVISION: 9/28/2023

Model/Feature Information

Model:		C56043 K56043
Cab:		CREW CAB
Aftertreatment:		HORIZONTAL
Fuel Tank:	RPO N2L	40 GAL, AF MTD
Battery Box:	RPO 7Y7/7Y8	28" STEEL, 2 BATTERIES
Air Tanks:		(1) OUTSIDE LEFT
DEF Tank:		6.75 GAL
Engine:		6.6L GM DURAMAX

General Configuration Information

4X2 TRUCK CONFIGURATION
 REAR AIR SUSPENSION
 SIDE EXIT TAILPIPE AHEAD OF REAR WHEELS, RT SIDE (RPO NPK)
 OPTIONAL AIR DRYER FWD OUTSIDE RT (RPO KUT/JPY)

Minimum Wheelbase

235" WB (120" CA)
 75" AF

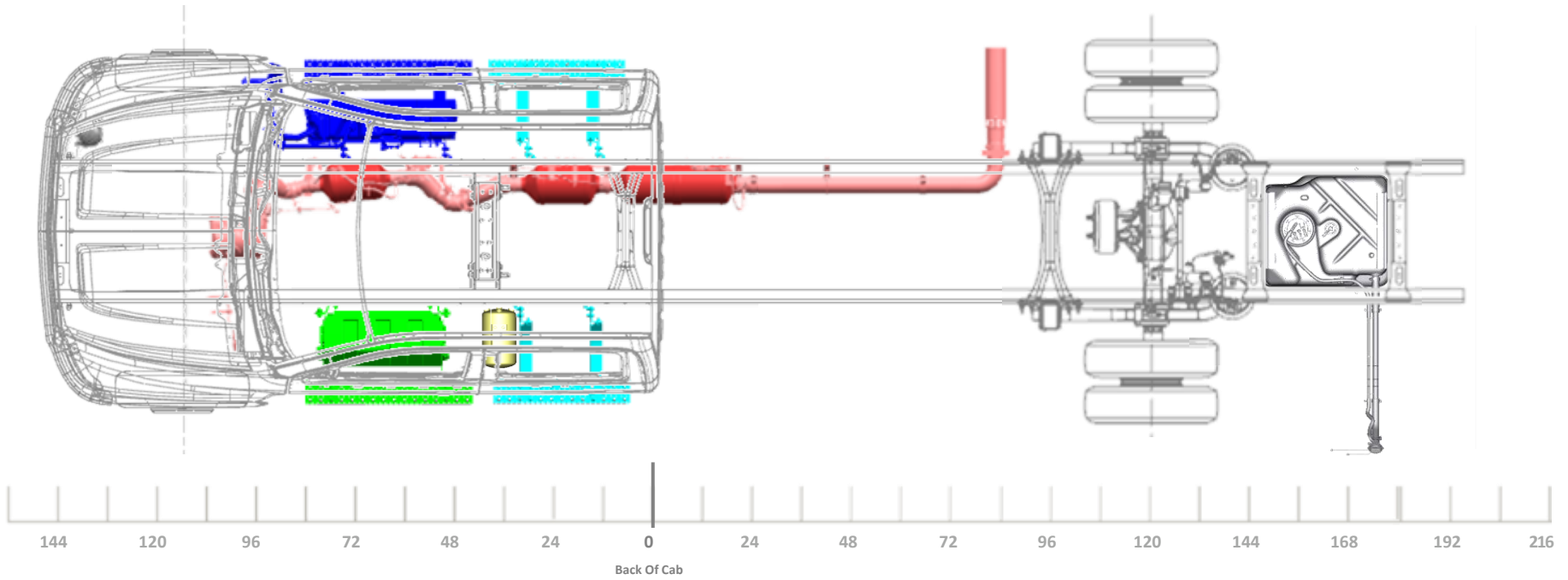

LAST REVISION: 9/28/2023

Model/Feature Information

Model:		C56043 K56043
Cab:		CREW CAB
Aftertreatment:		HORIZONTAL
Fuel Tank:	RPO N2L	40 GAL, AF MTD
Battery Box:	RPO 7Y9	TEMP MTD, 3 BATT
Air Tanks:		(1) OUTSIDE LEFT
DEF Tank:		6.75 GAL
Engine:		6.6L GM DURAMAX

General Configuration Information

4X2 OR 4X4 TRUCK CONFIGURATION
 VARI-RATE REAR SUSPENSION
 SIDE EXIT TAILPIPE AHEAD OF REAR WHEELS, RT SIDE (RPO NPK)
 OPTIONAL AIR DRYER FWD OUTSIDE RT (RPO KUT/JPY)

Minimum Wheelbase

235" WB (120" CA)
 75" AF

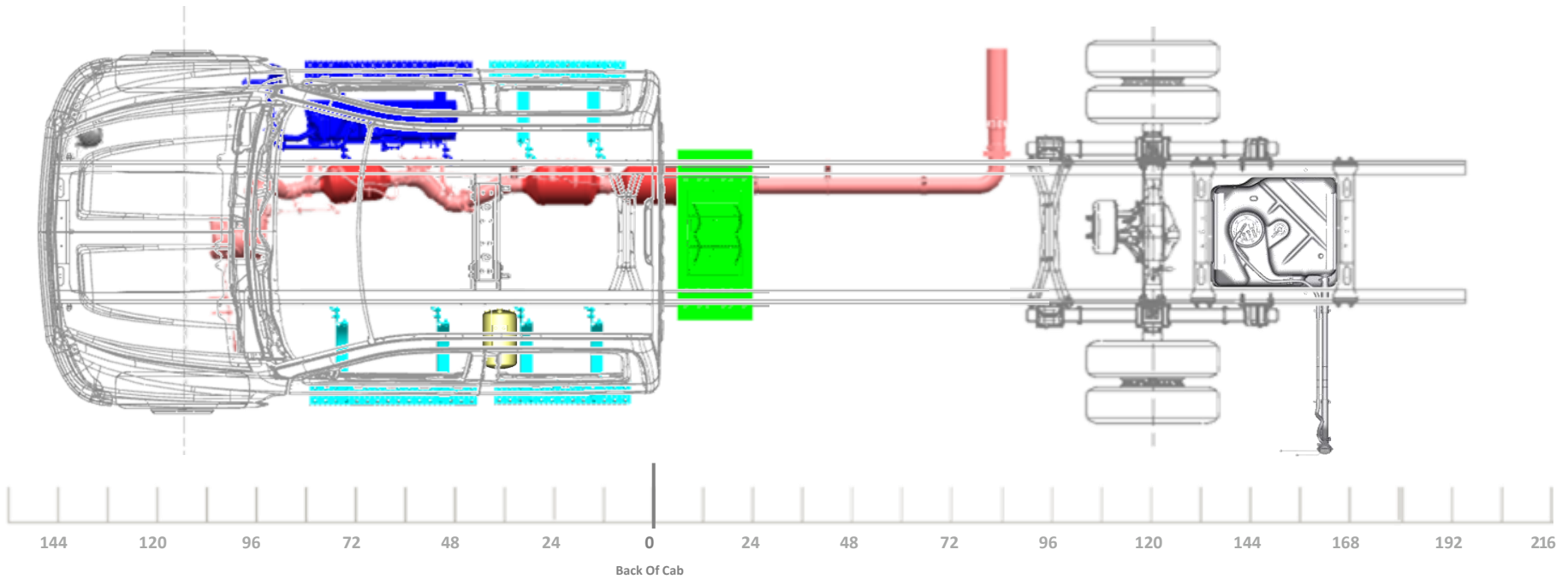

LAST REVISION: 9/28/2023

Model/Feature Information

Model:		C56043 K56043
Cab:		CREW CAB
Aftertreatment:		HORIZONTAL
Fuel Tank:	RPO N2L	40 GAL, AF MTD
Battery Box:	RPO 7Y9	TEMP MTD, 3 BATT
Air Tanks:		(1) OUTSIDE LEFT
DEF Tank:		6.75 GAL
Engine:		6.6L GM DURAMAX

General Configuration Information

4X2 TRUCK CONFIGURATION
 REAR AIR SUSPENSION
 SIDE EXIT TAILPIPE AHEAD OF REAR WHEELS, RT SIDE (RPO NPK)
 OPTIONAL AIR DRYER FWD OUTSIDE RT (RPO KUT/JPY)

Minimum Wheelbase

235" WB (120" CA)
 75" AF

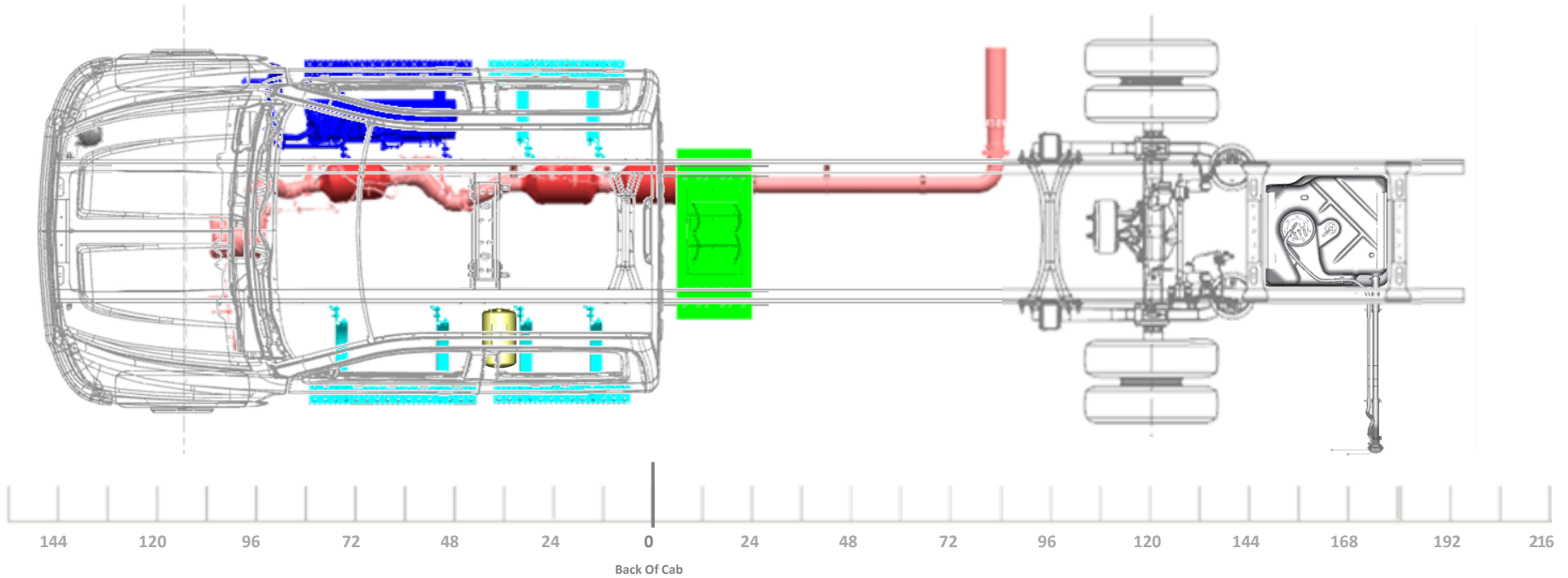

LAST REVISION: 9/28/2023

Model/Feature Information

Model:		C56043 K56043
Cab:		CREW CAB
Aftertreatment:		HORIZONTAL
Fuel Tank:	RPO NVK	25 GAL, CA MTD
Battery Box:	RPO 7Y7/7Y8	28" STEEL, 2 BATTERIES
Air Tanks:		(1) OUTSIDE LEFT
DEF Tank:		6.75 GAL
Engine:		6.6L GM DURAMAX

General Configuration Information

4X2 OR 4X4 TRUCK CONFIGURATION
 VARI-RATE REAR SUSPENSION

STRAIGHT TAILPIPE (RPO N12)

OPTIONAL AIR DRYER FWD OUTSIDE
 RT (RPO KUT/JPY)

Minimum Wheelbase

235" WB (120" CA)
 75" AF

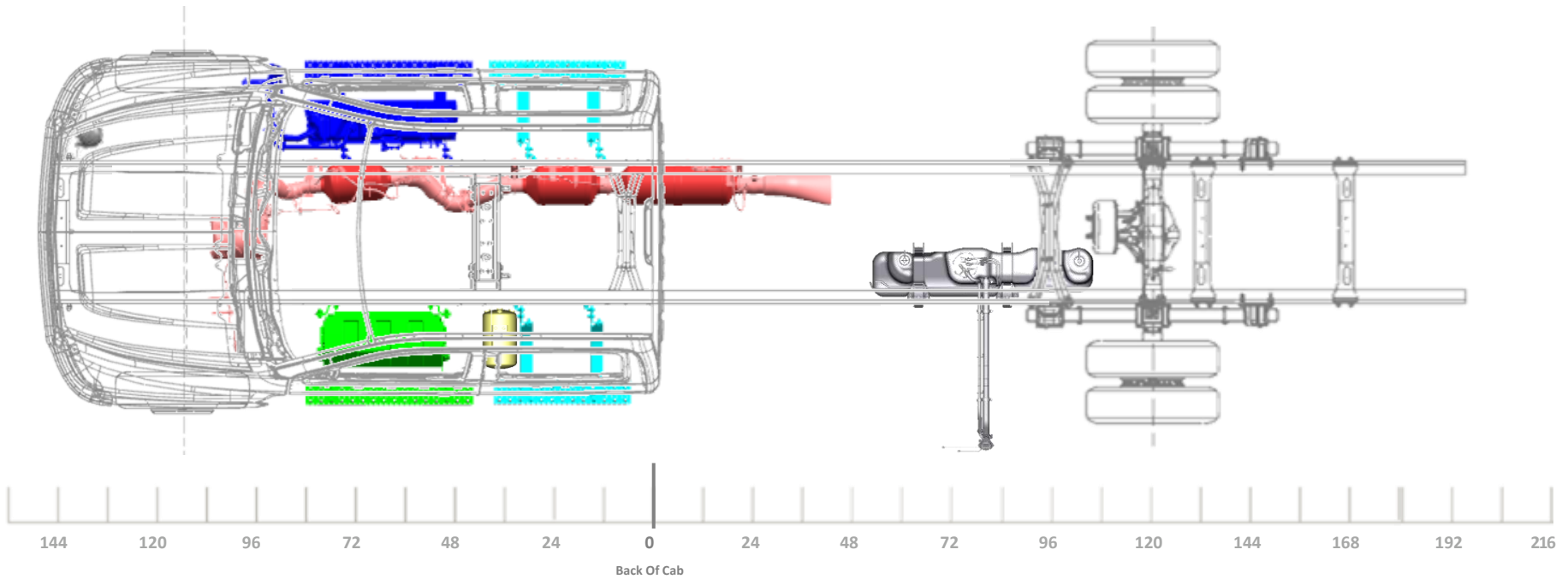

LAST REVISION: 9/28/2023

Model/Feature Information

Model:		C56043 K56043
Cab:		CREW CAB
Aftertreatment:		HORIZONTAL
Fuel Tank:	RPO NVK	25 GAL, CA MTD
Battery Box:	RPO 7Y7/7Y8	28" STEEL, 2 BATTERIES
Air Tanks:		(1) OUTSIDE LEFT
DEF Tank:		6.75 GAL
Engine:		6.6L GM DURAMAX

General Configuration Information

4X2 TRUCK CONFIGURATION
REAR AIR SUSPENSION
STRAIGHT TAILPIPE (RPO N12)
OPTIONAL AIR DRYER FWD OUTSIDE RT (RPO KUT/JPY)

Minimum Wheelbase

235" WB (120" CA)
75" AF

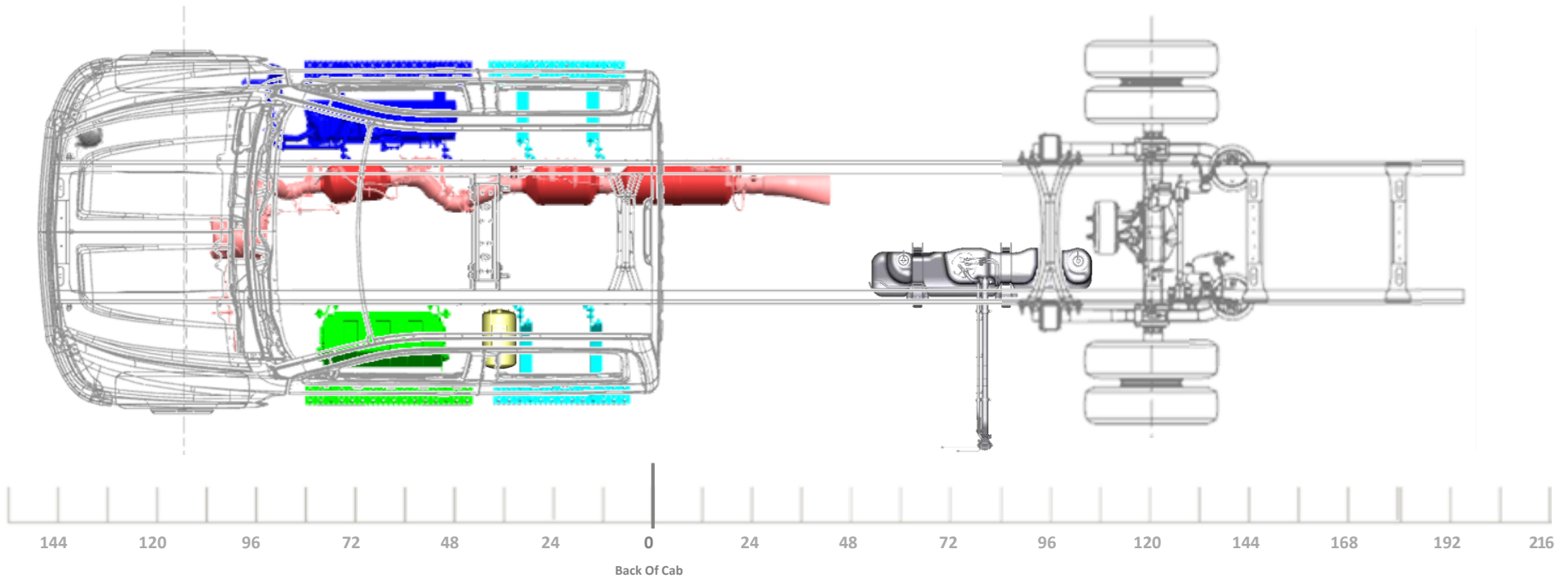

LAST REVISION: 9/28/2023

Model/Feature Information

Model:		C56043 K56043
Cab:		CREW CAB
Aftertreatment:		HORIZONTAL
Fuel Tank:	RPO NVK	25 GAL, CA MTD
Battery Box:	RPO 7Y9	TEMP MTD, 3 BATT
Air Tanks:		(1) OUTSIDE LEFT
DEF Tank:		6.75 GAL
Engine:		6.6L GM DURAMAX

General Configuration Information

4X2 OR 4X4 TRUCK CONFIGURATION
 VARI-RATE REAR SUSPENSION

STRAIGHT TAILPIPE (RPO N12)

OPTIONAL AIR DRYER FWD OUTSIDE
 RT (RPO KUT/JPY)

Minimum Wheelbase

235" WB (120" CA)
 75" AF

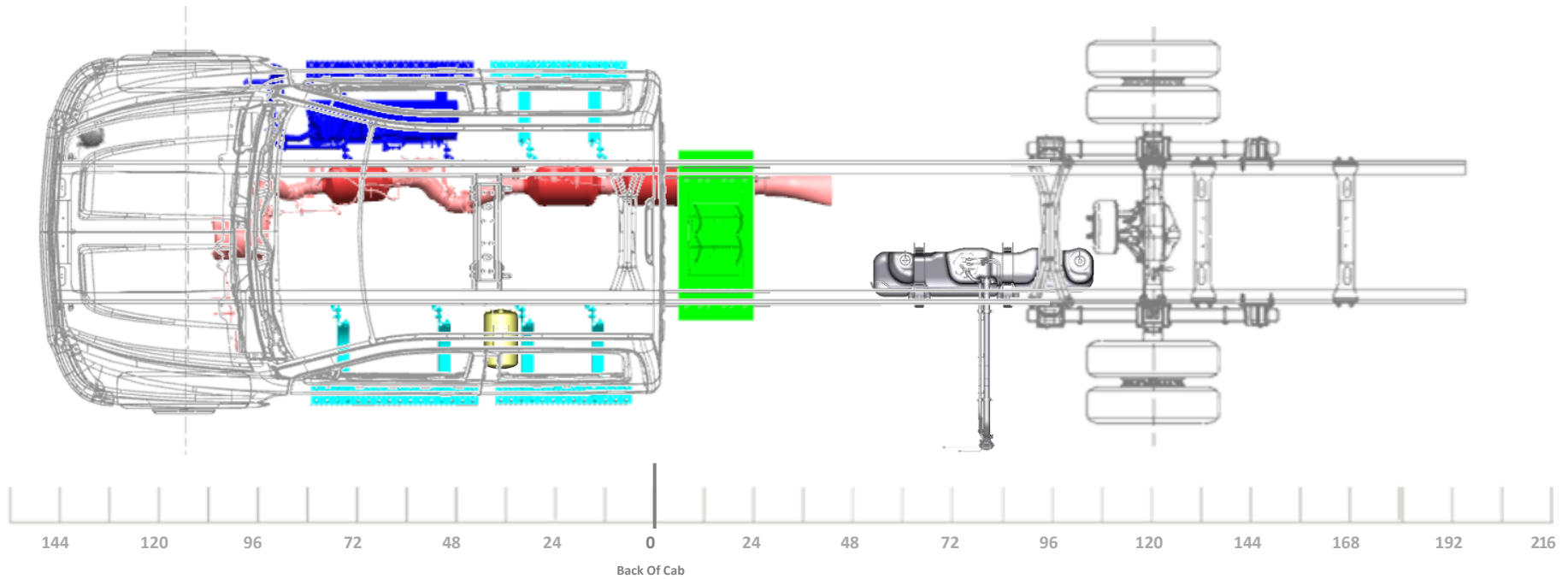

LAST REVISION: 9/28/2023

Model/Feature Information

Model:		C56043 K56043
Cab:		CREW CAB
Aftertreatment:		HORIZONTAL
Fuel Tank:	RPO NVK	25 GAL, CA MTD
Battery Box:	RPO 7Y9	TEMP MTD, 3 BATT
Air Tanks:		(1) OUTSIDE LEFT
DEF Tank:		6.75 GAL
Engine:		6.6L GM DURAMAX

General Configuration Information

4X2 TRUCK CONFIGURATION
REAR AIR SUSPENSION
STRAIGHT TAILPIPE (RPO N12)
OPTIONAL AIR DRYER FWD OUTSIDE RT (RPO KUT/JPY)

Minimum Wheelbase

235" WB (120" CA)
75" AF

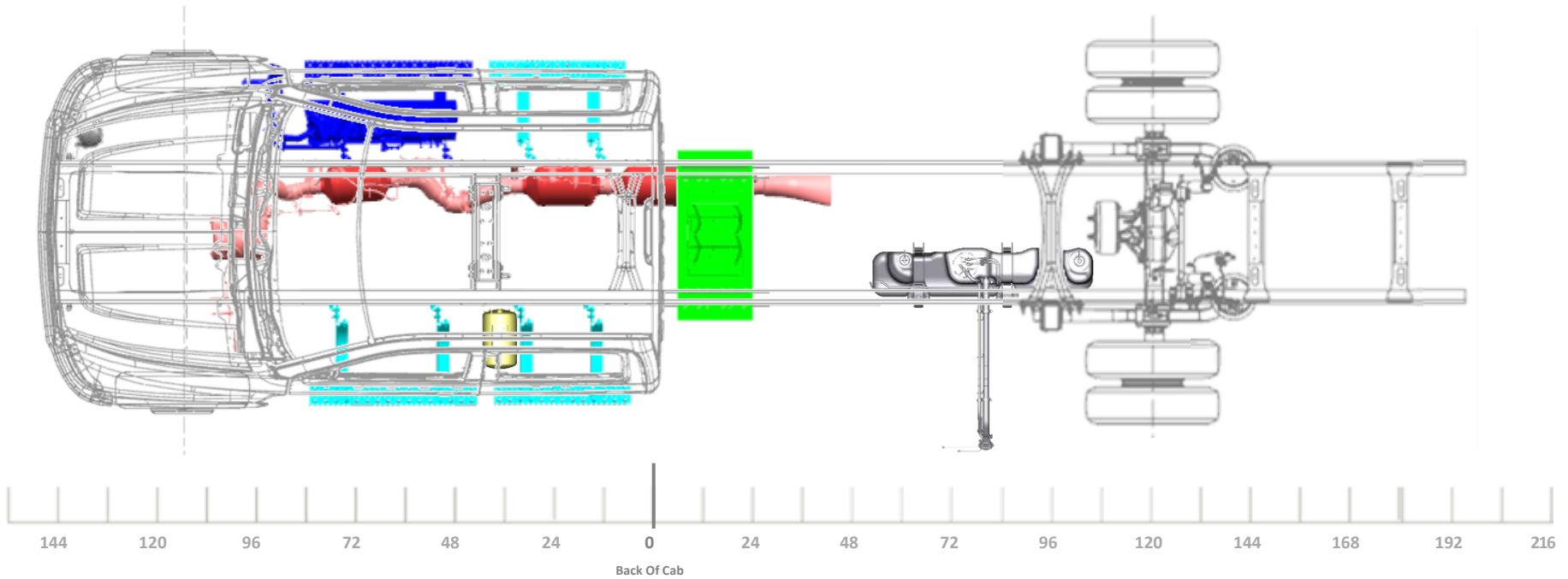

LAST REVISION: 9/28/2023

Model/Feature Information

Model:	C56043 K56043	
Cab:	CREW CAB	
Aftertreatment:	HORIZONTAL	
Fuel Tank:	RPO NVK	25 GAL, CA MTD
Battery Box:	RPO 7Y7/7Y8	28" STEEL, 2 BATTERIES
Air Tanks:	(1) OUTSIDE LEFT	
DEF Tank:	6.75 GAL	
Engine:	6.6L GM DURAMAX	

General Configuration Information

4X2 OR 4X4 TRUCK CONFIGURATION
 VARI-RATE REAR SUSPENSION

SIDE EXIT TAILPIPE AHEAD OF REAR
 WHEELS, RT SIDE (RPO NPK)

OPTIONAL AIR DRYER FWD OUTSIDE
 RT (RPO KUT/JPY)

Minimum Wheelbase

235" WB (120" CA)
 75" AF

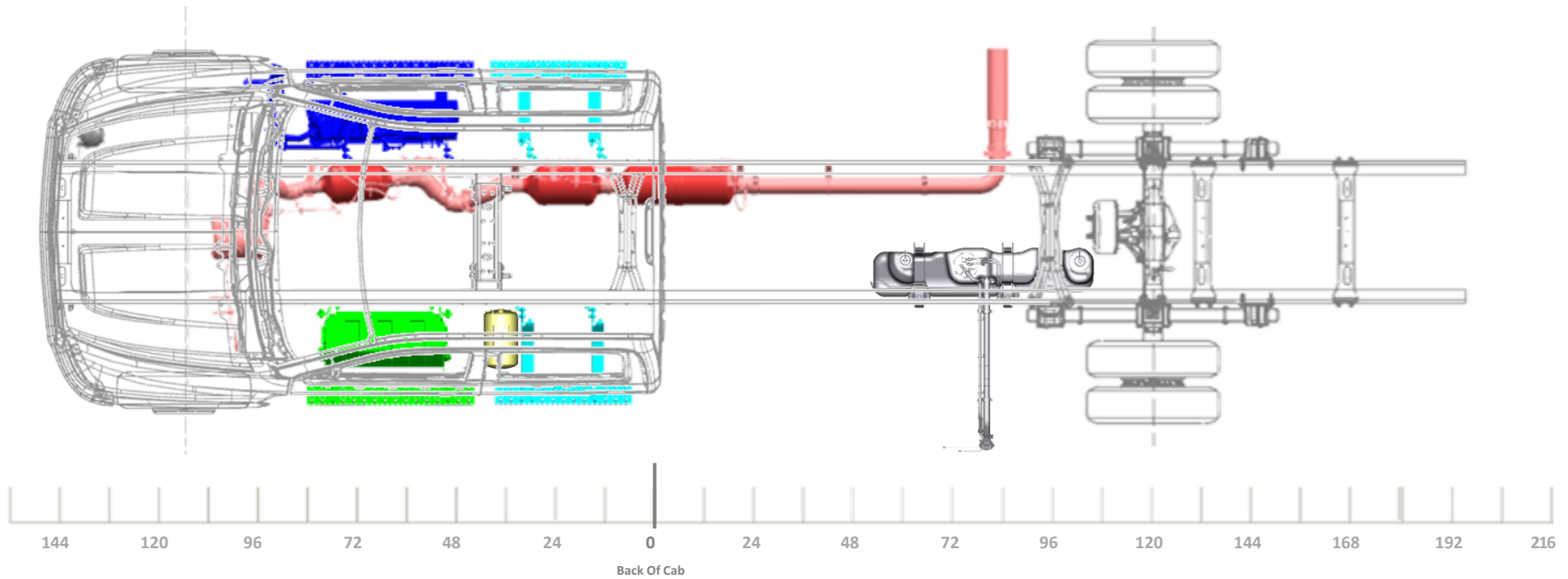

LAST REVISION: 9/28/2023

Model/Feature Information

Model:		C56043 K56043
Cab:		CREW CAB
Aftertreatment:		HORIZONTAL
Fuel Tank:	RPO NVK	25 GAL, CA MTD
Battery Box:	RPO 7Y7/7Y8	28" STEEL, 2 BATTERIES
Air Tanks:		(1) OUTSIDE LEFT
DEF Tank:		6.75 GAL
Engine:		6.6L GM DURAMAX

General Configuration Information

4X2 TRUCK CONFIGURATION
 REAR AIR SUSPENSION
 SIDE EXIT TAILPIPE AHEAD OF REAR WHEELS, RT SIDE (RPO NPK)
 OPTIONAL AIR DRYER FWD OUTSIDE RT (RPO KUT/JPY)

Minimum Wheelbase

235" WB (120" CA)
 75" AF

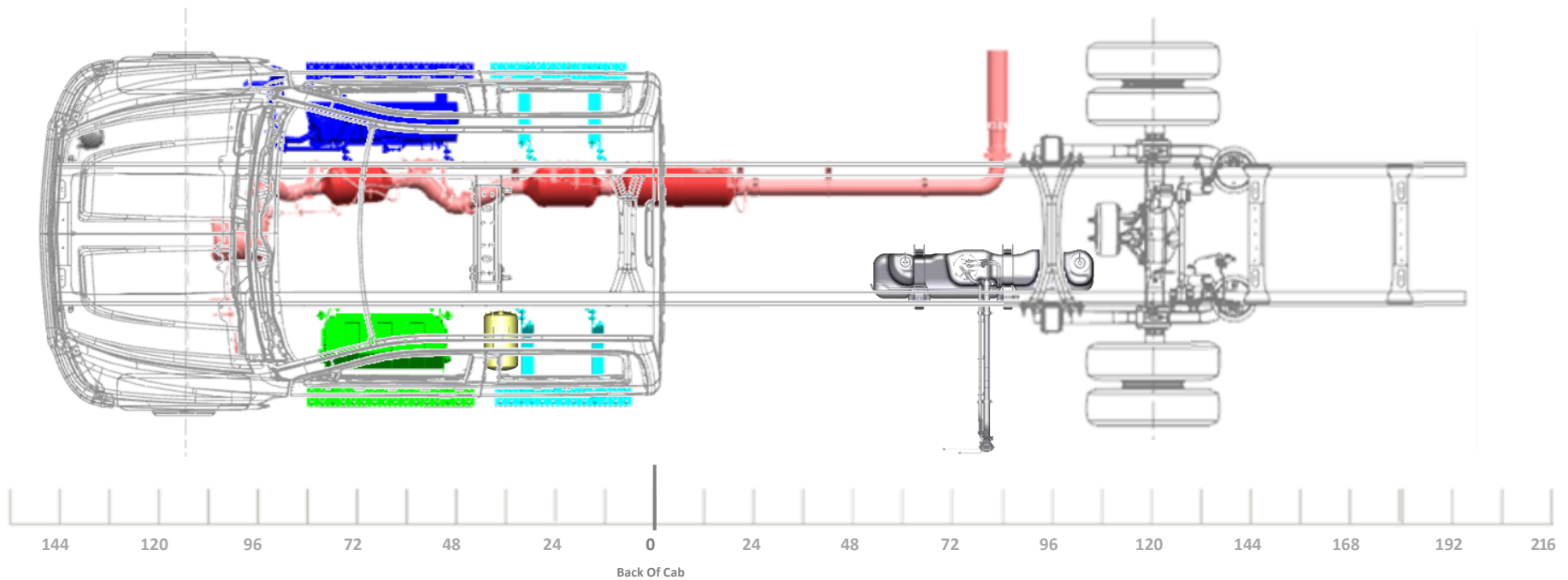

LAST REVISION: 9/28/2023

Model/Feature Information

Model:		C56043 K56043
Cab:		CREW CAB
Aftertreatment:		HORIZONTAL
Fuel Tank:	RPO NVK	25 GAL, CA MTD
Battery Box:	RPO 7Y9	TEMP MTD, 3 BATT
Air Tanks:		(1) OUTSIDE LEFT
DEF Tank:		6.75 GAL
Engine:		6.6L GM DURAMAX

General Configuration Information

4X2 OR 4X4 TRUCK CONFIGURATION
 VARI-RATE REAR SUSPENSION

SIDE EXIT TAILPIPE AHEAD OF REAR
 WHEELS, RT SIDE (RPO NPK)

OPTIONAL AIR DRYER FWD OUTSIDE
 RT (RPO KUT/JPY)

Minimum Wheelbase

235" WB (120" CA)
 75" AF

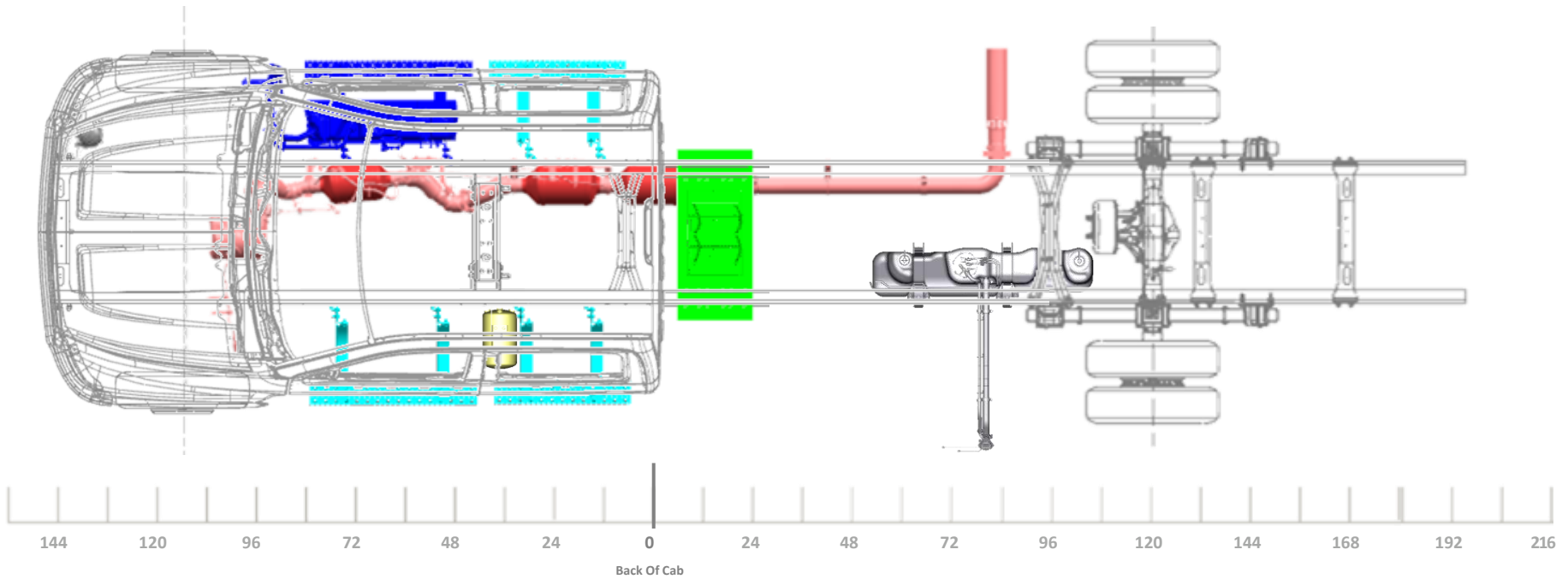

LAST REVISION: 9/28/2023

Model/Feature Information

Model:		C56043 K56043
Cab:		CREW CAB
Aftertreatment:		HORIZONTAL
Fuel Tank:	RPO NVK	25 GAL, CA MTD
Battery Box:	RPO 7Y9	TEMP MTD, 3 BATT
Air Tanks:		(1) OUTSIDE LEFT
DEF Tank:		6.75 GAL
Engine:		6.6L GM DURAMAX

General Configuration Information

4X2 TRUCK CONFIGURATION
 REAR AIR SUSPENSION
 SIDE EXIT TAILPIPE AHEAD OF REAR WHEELS, RT SIDE (RPO NPK)
 OPTIONAL AIR DRYER FWD OUTSIDE RT (RPO KUT/JPY)

Minimum Wheelbase

235" WB (120" CA)
 75" AF

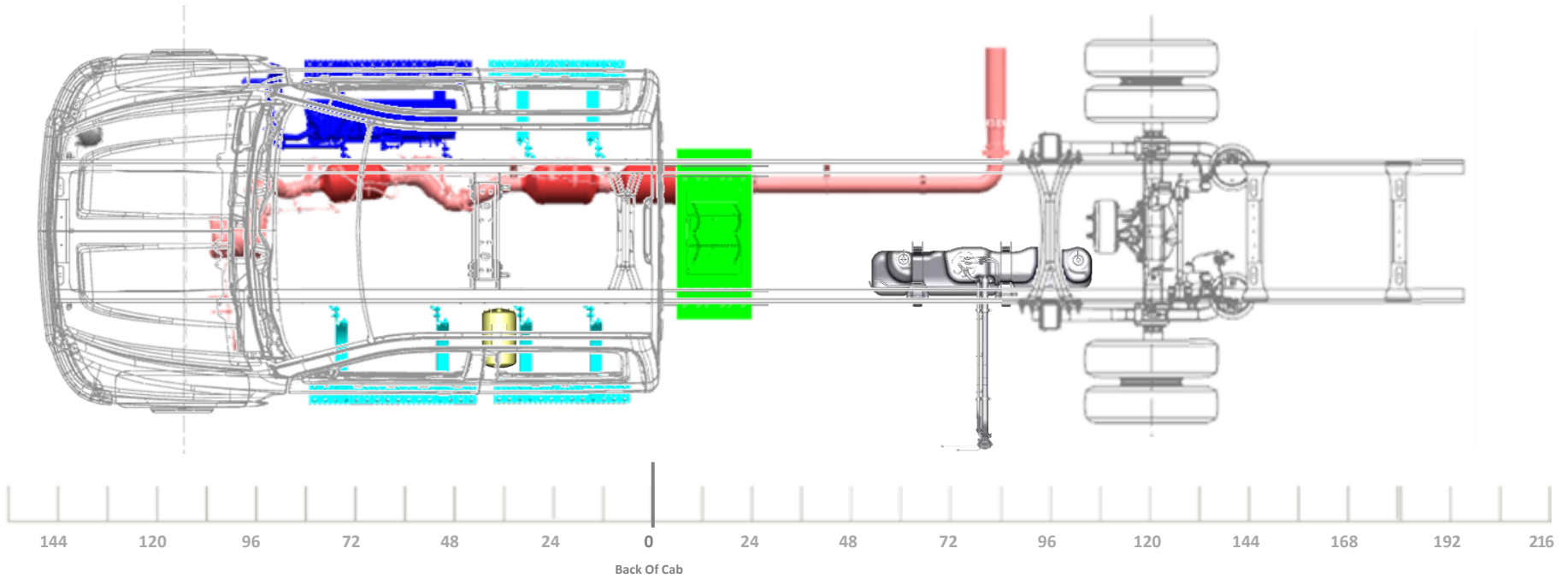

LAST REVISION: 9/28/2023

Model/Feature Information

Model:		C56043 K56043
Cab:		CREW CAB
Aftertreatment:		HORIZONTAL
Fuel Tank:	RPO NSQ	DUAL 25G CA, 40G AF
Battery Box:	RPO 7Y7/7Y8	28" STEEL, 2 BATTERIES
Air Tanks:		(1) OUTSIDE LEFT
DEF Tank:		6.75 GAL
Engine:		6.6L GM DURAMAX

General Configuration Information

4X2 OR 4X4 TRUCK CONFIGURATION
 VARI-RATE REAR SUSPENSION

STRAIGHT TAILPIPE (RPO N12)

OPTIONAL AIR DRYER FWD OUTSIDE
 RT (RPO KUT/JPY)

Minimum Wheelbase

235" WB (120" CA)
 75" AF

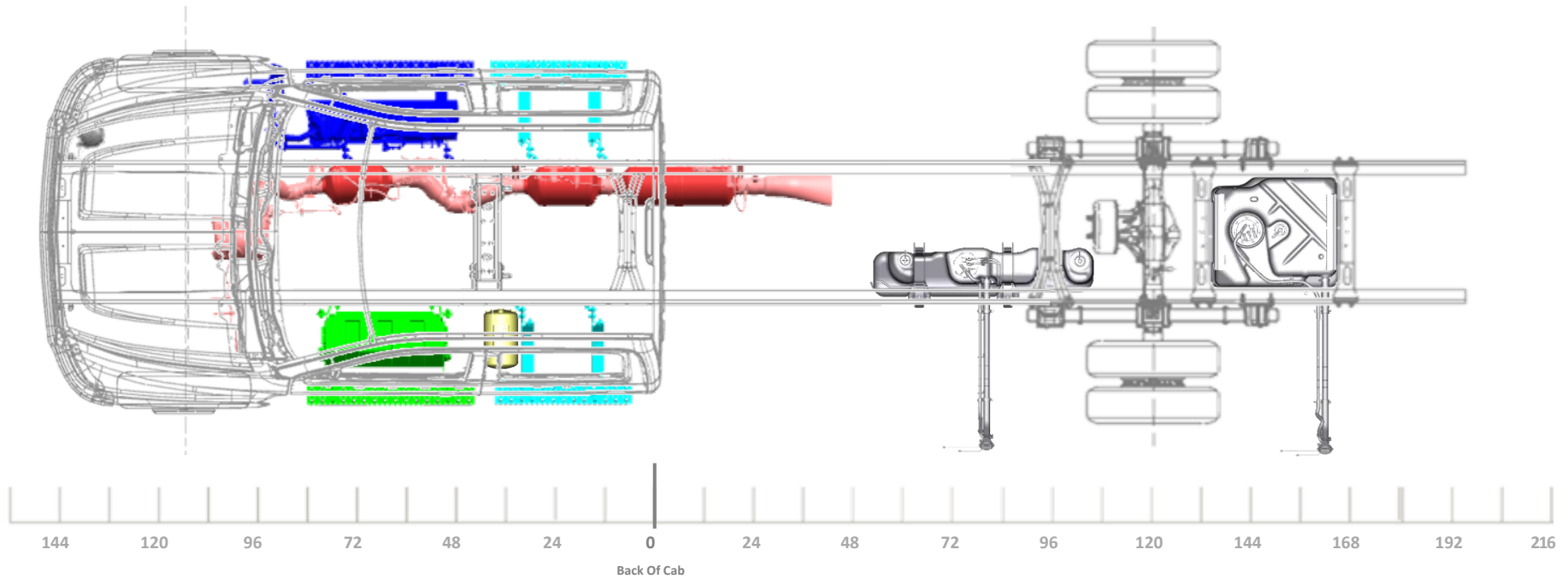

LAST REVISION: 9/28/2023

Model/Feature Information

Model:		C56043 K56043
Cab:		CREW CAB
Aftertreatment:		HORIZONTAL
Fuel Tank:	RPO NSQ	DUAL 25G CA, 40G AF
Battery Box:	RPO 7Y7/7Y8	28" STEEL, 2 BATTERIES
Air Tanks:		(1) OUTSIDE LEFT
DEF Tank:		6.75 GAL
Engine:		6.6L GM DURAMAX

General Configuration Information

4X2 TRUCK CONFIGURATION
REAR AIR SUSPENSION
STRAIGHT TAILPIPE (RPO N12)
OPTIONAL AIR DRYER FWD OUTSIDE RT (RPO KUT/JPY)

Minimum Wheelbase

235" WB (120" CA)
75" AF

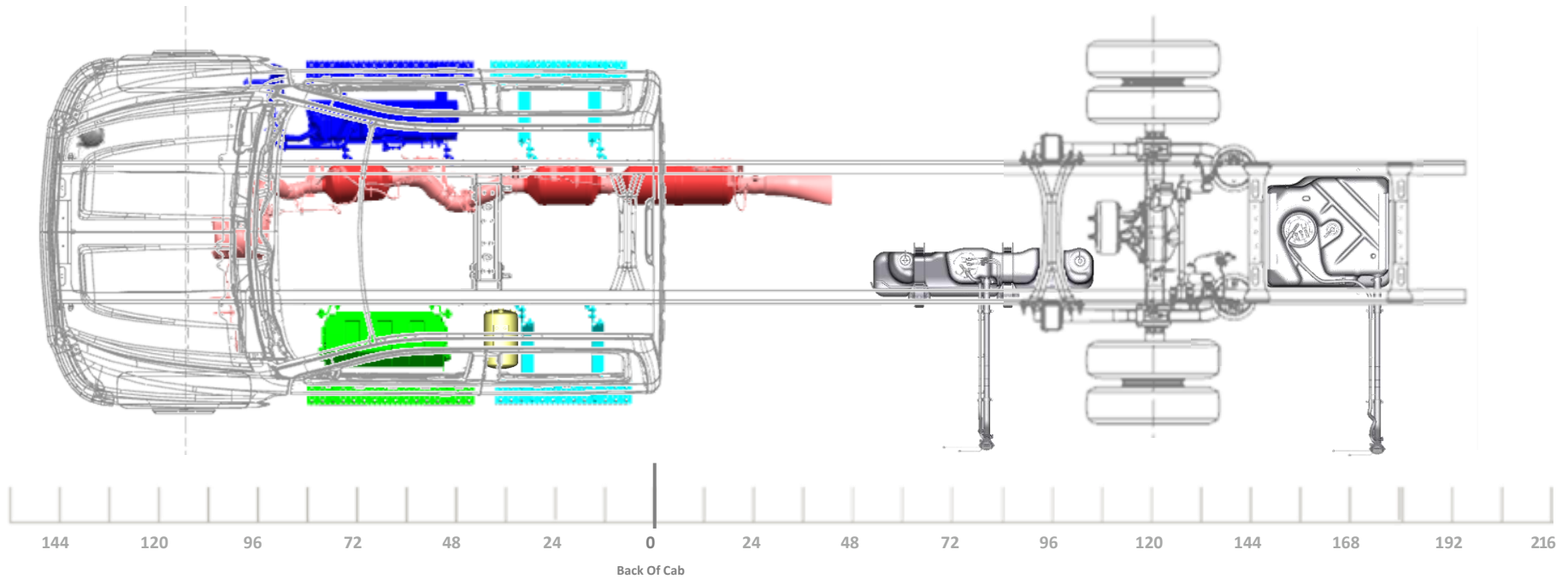

LAST REVISION: 9/28/2023

Model/Feature Information

Model:		C56043 K56043
Cab:		CREW CAB
Aftertreatment:		HORIZONTAL
Fuel Tank:	RPO NSQ	DUAL 25G CA, 40G AF
Battery Box:	RPO 7Y9	TEMP MTD, 3 BATT
Air Tanks:		(1) OUTSIDE LEFT
DEF Tank:		6.75 GAL
Engine:		6.6L GM DURAMAX

General Configuration Information

4X2 OR 4X4 TRUCK CONFIGURATION
 VARI-RATE REAR SUSPENSION

STRAIGHT TAILPIPE (RPO N12)

OPTIONAL AIR DRYER FWD OUTSIDE
 RT (RPO KUT/JPY)

Minimum Wheelbase

235" WB (120" CA)
 75" AF

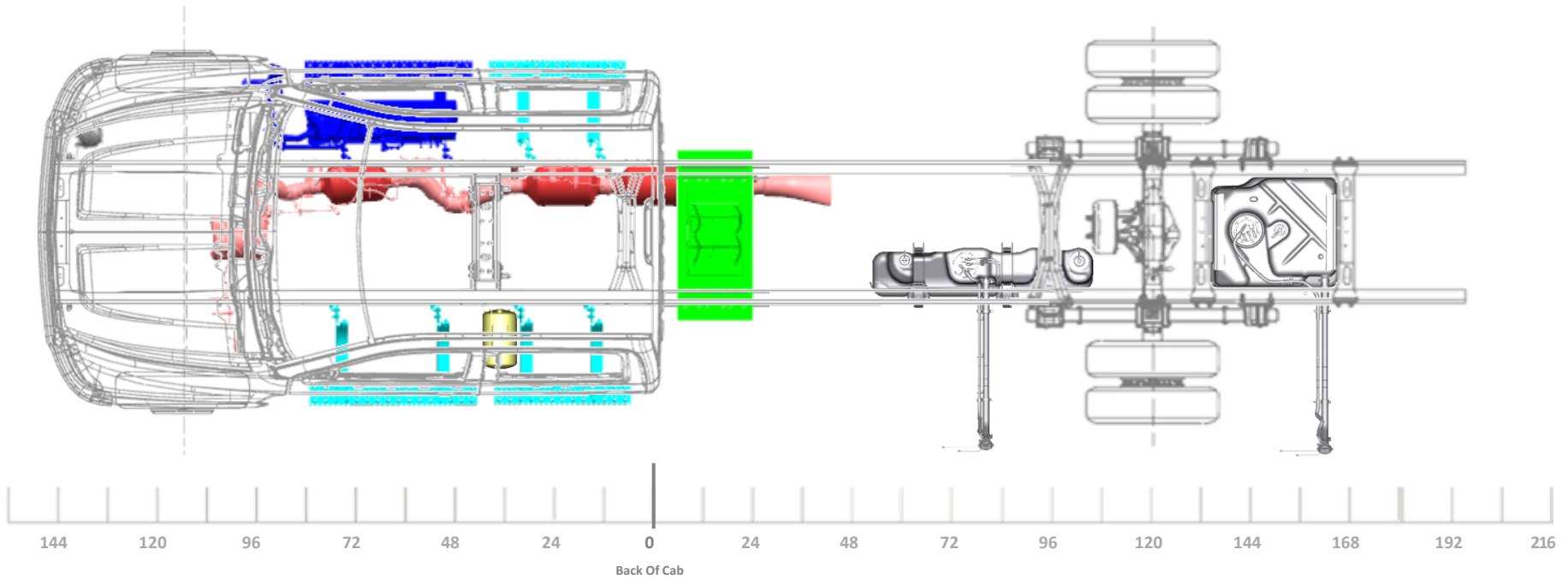

LAST REVISION: 9/28/2023

Model/Feature Information

Model:		C56043 K56043
Cab:		CREW CAB
Aftertreatment:		HORIZONTAL
Fuel Tank:	RPO NSQ	DUAL 25G CA, 40G AF
Battery Box:	RPO 7Y9	TEMP MTD, 3 BATT
Air Tanks:		(1) OUTSIDE LEFT
DEF Tank:		6.75 GAL
Engine:		6.6L GM DURAMAX

General Configuration Information

4X2 TRUCK CONFIGURATION
REAR AIR SUSPENSION
STRAIGHT TAILPIPE (RPO N12)
OPTIONAL AIR DRYER FWD OUTSIDE RT (RPO KUT/JPY)

Minimum Wheelbase

235" WB (120" CA)
75" AF

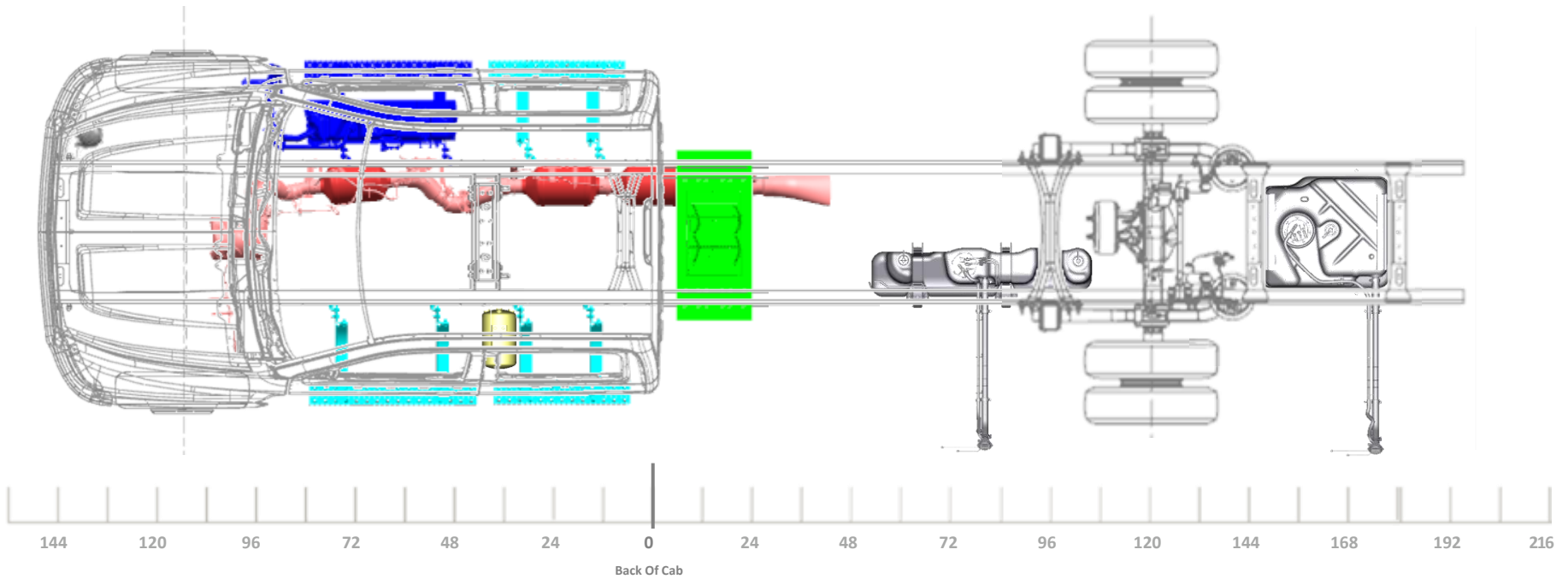

LAST REVISION: 9/28/2023

Model/Feature Information

Model:		C56043 K56043
Cab:		CREW CAB
Aftertreatment:		HORIZONTAL
Fuel Tank:	RPO NSQ	DUAL 25G CA, 40G AF
Battery Box:	RPO 7Y7/7Y8	28" STEEL, 2 BATTERIES
Air Tanks:		(1) OUTSIDE LEFT
DEF Tank:		6.75 GAL
Engine:		6.6L GM DURAMAX

General Configuration Information

4X2 OR 4X4 TRUCK CONFIGURATION
 VARI-RATE REAR SUSPENSION

SIDE EXIT TAILPIPE AHEAD OF REAR
 WHEELS, RT SIDE (RPO NPK)

OPTIONAL AIR DRYER FWD OUTSIDE
 RT (RPO KUT/JPY)

Minimum Wheelbase

235" WB (120" CA)
 75" AF

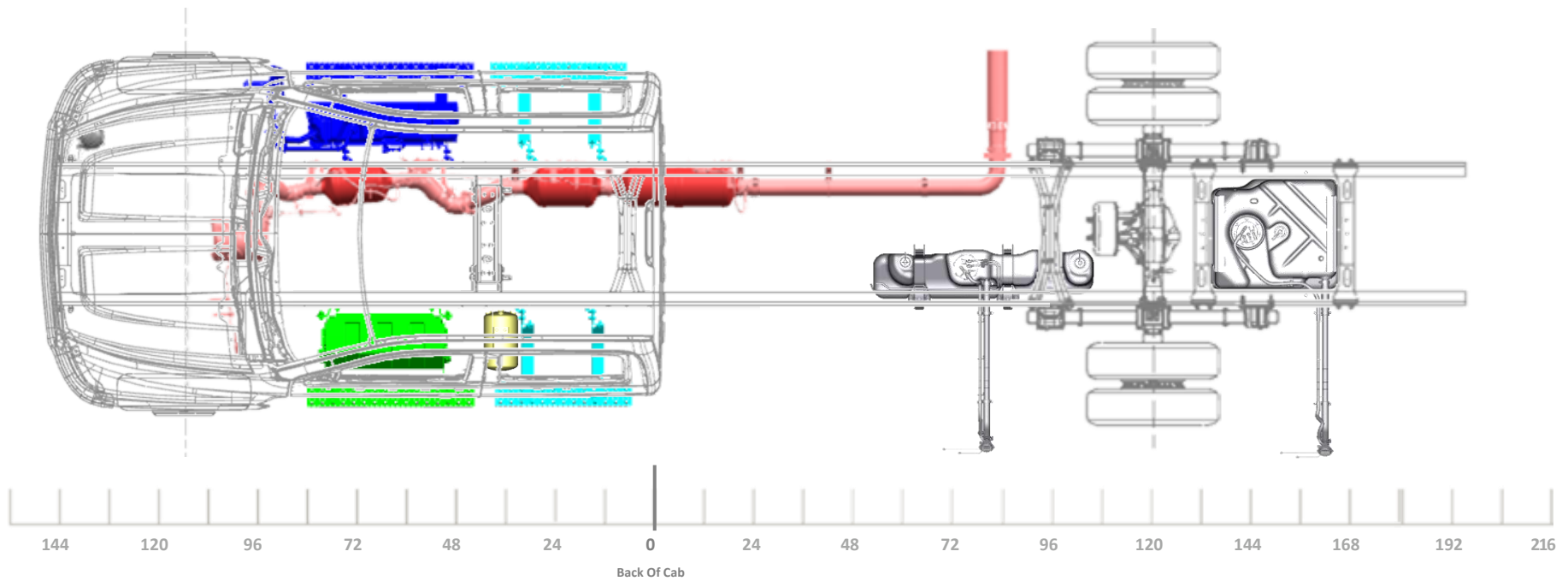

LAST REVISION: 9/28/2023

Model/Feature Information

Model:		C56043 K56043
Cab:		CREW CAB
Aftertreatment:		HORIZONTAL
Fuel Tank:	RPO NSQ	DUAL 25G CA, 40G AF
Battery Box:	RPO 7Y7/7Y8	28" STEEL, 2 BATTERIES
Air Tanks:		(1) OUTSIDE LEFT
DEF Tank:		6.75 GAL
Engine:		6.6L GM DURAMAX

General Configuration Information

4X2 TRUCK CONFIGURATION
REAR AIR SUSPENSION
SIDE EXIT TAILPIPE AHEAD OF REAR WHEELS, RT SIDE (RPO NPK)
OPTIONAL AIR DRYER FWD OUTSIDE RT (RPO KUT/JPY)

Minimum Wheelbase

235" WB (120" CA)
75" AF

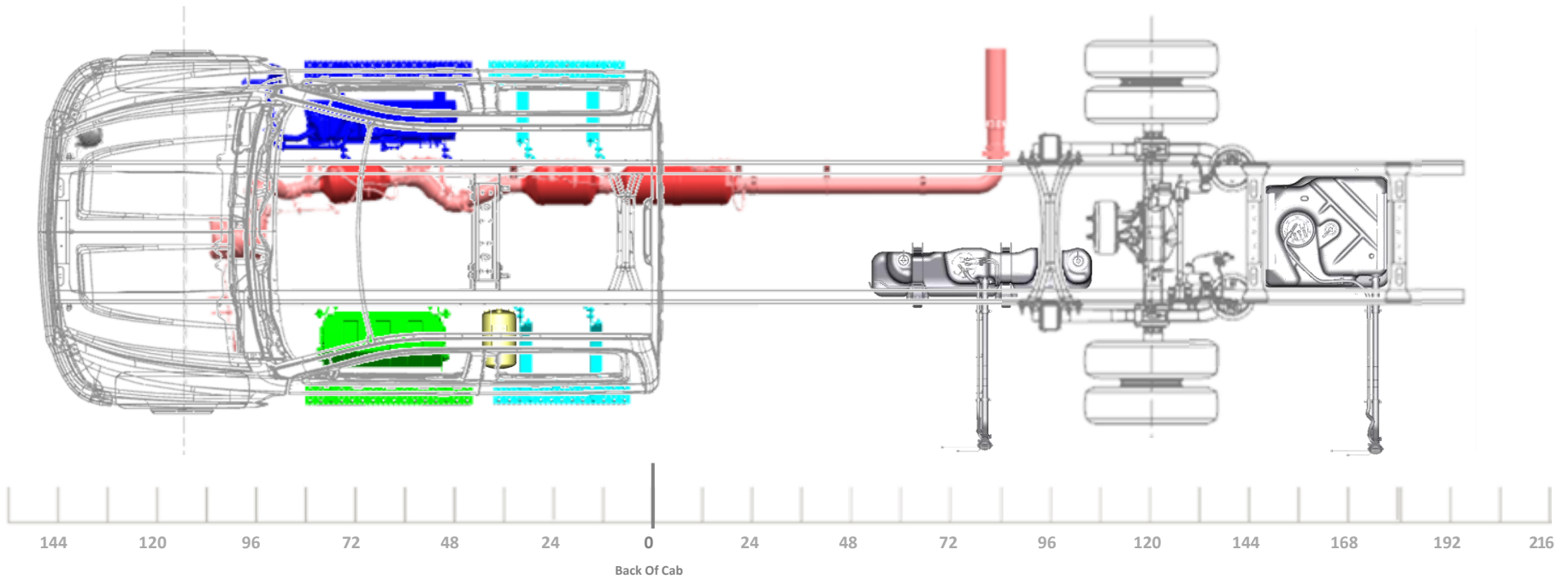

LAST REVISION: 9/28/2023

Model/Feature Information

Model:		C56043 K56043
Cab:		CREW CAB
Aftertreatment:		HORIZONTAL
Fuel Tank:	RPO NSQ	DUAL 25G CA, 40G AF
Battery Box:	RPO 7Y9	TEMP MTD, 3 BATT
Air Tanks:		(1) OUTSIDE LEFT
DEF Tank:		6.75 GAL
Engine:		6.6L GM DURAMAX

General Configuration Information

4X2 OR 4X4 TRUCK CONFIGURATION
 VARI-RATE REAR SUSPENSION

SIDE EXIT TAILPIPE AHEAD OF REAR WHEELS, RT SIDE (RPO NPK)

OPTIONAL AIR DRYER FWD OUTSIDE RT (RPO KUT/JPY)

Minimum Wheelbase

235" WB (120" CA)
 75" AF

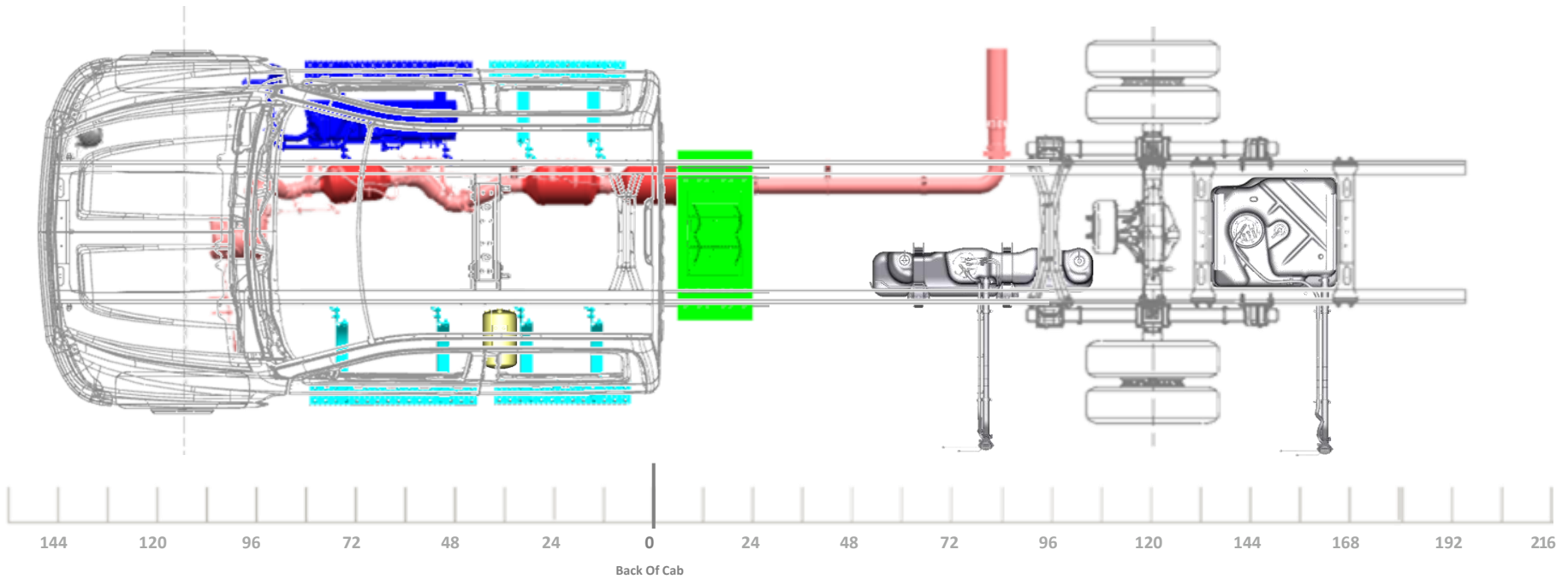

LAST REVISION: 9/28/2023

Model/Feature Information

Model:		C56043 K56043
Cab:		CREW CAB
Aftertreatment:		HORIZONTAL
Fuel Tank:	RPO NSQ	DUAL 25G CA, 40G AF
Battery Box:	RPO 7Y9	TEMP MTD, 3 BATT
Air Tanks:		(1) OUTSIDE LEFT
DEF Tank:		6.75 GAL
Engine:		6.6L GM DURAMAX

General Configuration Information

4X2 TRUCK CONFIGURATION
 REAR AIR SUSPENSION

SIDE EXIT TAILPIPE AHEAD OF REAR WHEELS, RT SIDE (RPO NPK)

OPTIONAL AIR DRYER FWD OUTSIDE RT (RPO KUT/JPY)

Minimum Wheelbase

235" WB (120" CA)
 75" AF

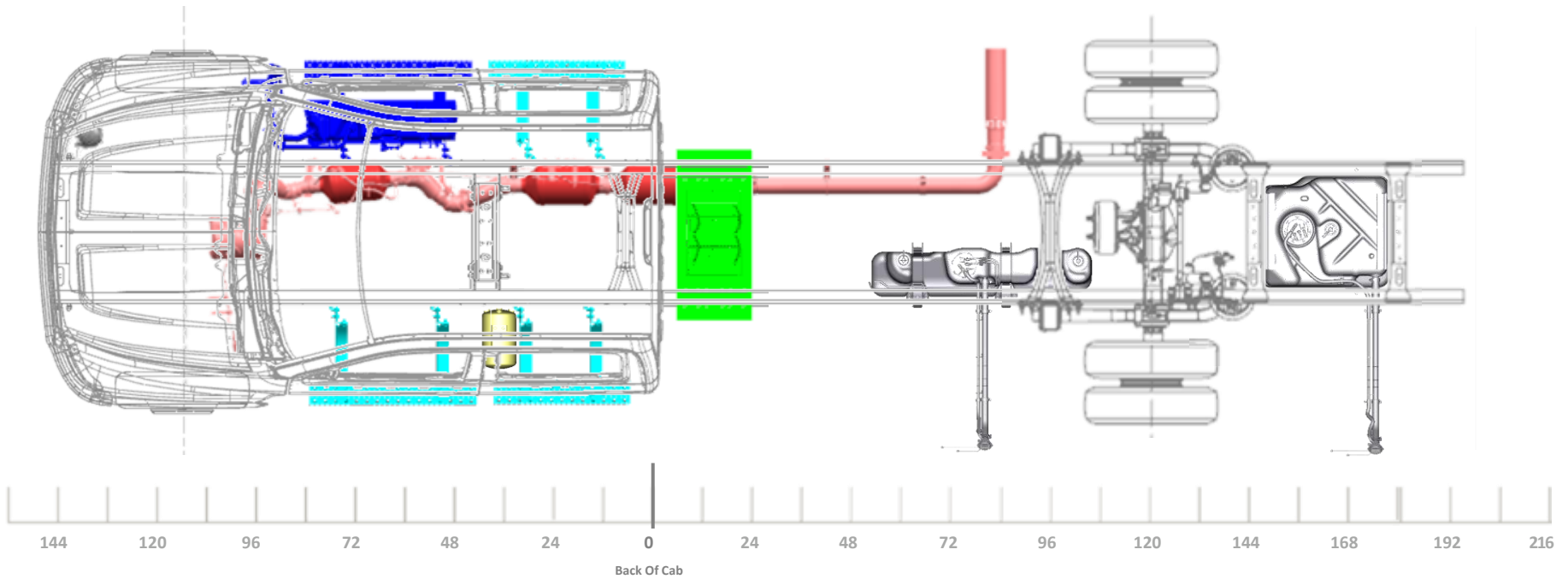

LAST REVISION: 9/28/2023